



MUNICIPAL CORPORATION OF GREATER MUMBAI

BID DOCUMENT

E-TENDER

FOR

Name of Work: CT - 60: Work of construction of RCC box drain of size 4 m x 2m along Sion Mahim- link road from Piwala Bunglow up to T-junction in G/N ward.

Website: portal.mcgm.gov.in/tenders

Office of : **Dy.Chief Engineer (Storm Water Drains)City**

Engineering Hub Building,

Ground Floor, Dr. E. Moses Road,

Worli Naka, Worli, Mumbai- 400 018.

INDEX

SECTION	DESCRIPTION	Pg. No.
1	E-TENDER NOTICE	03 - 07
2	ELIGIBILITY CRITERIA	08 - 11
3	DISCLAIMER	12 - 13
4	INTRODUCTION	14 - 16
5	E-TENDERING ONLINE SUBMISSION PROCESS	17 - 20
6	INSTRUCTIONS TO APPLICANTS	21 - 51
7	SCOPE OF WORK	52 - 53
8	BILL OF QUANTITIES	54 - 75
9	GENERAL CONDITIONS OF CONTRACT	76 - 121
10	SPECIFICATIONS & SELECTION OF MATERIAL	122 - 123
11	FRAUD AND CORRUPT PRACTICES	124 - 127
12	PRE-BID MEETING	128 - 129
13	LIST OF APPROVED BANKS	130 - 133
14	APPENDIX	134 - 161
15	SPECIAL CONDITION OF CONTRACT	162 - 190
16	TYPICAL DRAWINGS	191 - 192
17	FINANCIAL BID FORM (FORM-B)	193 - 194
18	BARRICADING CIRCULAR	195 - 204

SECTION 1
E-TENDER NOTICE

MUNICIPAL CORPORATION OF GREATER MUMBAI

**Office of
Deputy Chief Engineer (Storm Water Drains) City**

No. MCGM/SWD/City/2022/CT-60

E-TENDER NOTICE

Subject: CT-60 work of construction of RCC box drain of size 4m x 2m along Sion - Mahim link road from piwala Bunglow up to T-Junction in G/N ward.

The Municipal Corporation of Greater Mumbai (MCGM) invites e-tender to appoint Contractor for the above mentioned work from contractors of repute, multidisciplinary engineering organizations i.e. eminent firm, Proprietary/Partnership Firms/ Private Limited Companies/ Public Limited Companies/Companies registered under the Indian companies Act 2013, the contractors registered with the Municipal Corporation of Greater Mumbai, (MCGM) in **Class I(A) as per new registration policy 2015 & 2016** and from the contractors/firms equivalent and superior classes registered in Central or State Government/Semi Govt. Organization/Central or State Public Sector Undertakings, will be allowed subject to condition that, the contractors who are not registered with MCGM will have to apply for registering their firm within three months' time period from the award of contract, otherwise their Bid Security i.e. E.M.D (Earnest Money Deposit) will be forfeited/recovered and a penalty of 0.1% of contract cost or Rs. 10,000/- whichever is more will be recovered/deducted from the contractor's bill/payment by the executed department in MCGM. Bidding Process will comprise of THREE stages.

The application form can be downloaded from MCGM's portal (<http://portal.mcg.gov.in>) on payment of Rs. **11,092/- (Rs.9400/- + 18% GST)**. The applicants not registered with MCGM are mandated to get registered (Vendor Registration) with MCGM for e-tendering process & obtain login credentials to participate in the online bidding process.

- i) To download the application form, for those applicants not having vendor registration, need to apply first for vendor registration at the office of Account Officer (FAR), 3rd floor, Municipal Headquarter.
- ii) Followed by SRM login ID and password to be obtained from Central Purchase Department (CPD), Office at Bakariadda, Byculla, Mumbai.
- iii) For e-Tendering registration, enrollment for digital signature certificates and user manual, please refer to respective links provided in 'Tenders' tab. Vendors can get digital signature from any one of the Certifying Authorities (CA's) licensed by controller of certifying authorities namely, Safes

crypt, IDRBT, National informatics center, TCS, CUSTOMS, MTNL, GNFC and e- Mudhra CA.

Name and Location of Work	Contract Period	Estimated Cost of Project
CT-60 work of construction of RCC box drain of size 4m x 2m along Sion- Mahim link road from piwala Bunglow up to T-Junction in G/N ward.	6 Months (Excluding Monsoon)	Rs. 33,99,12,418/-

iv) In terms of the 3 stage system of e-tendering, a Bidder will be required to deposit, along with its Bid, an Earnest Money Deposit of Rs. 33,99,200/- (Rupees Thirty three Lacs ninety nine Thousand Two hundred only) (the "EMD"), refundable in accordance to the relevant clause of bid document, from the Bid Due Date, except in the case of the selected Bidder whose Bid Security/EMD shall be retained. The Bidders will have to provide Earnest Money Deposit through the payment gateways while submitting the bids. The Bid shall be summarily rejected if it is not accompanied by the Earnest Money Deposit. The e-tender is available on MCGM portal (<http://portal.mcgm.gov.in>) as mentioned in the Header Data of the tender.

v) As per THREE Packet systems, the document for Packet A, Packet B & C is to be uploaded by the bidder in vendors' document online in Packet A, Packet B & C. Packet A, B & C shall be opened on dates as mentioned in header data. All the responsive and eligible bidders if they so wish can be present at the time of bids, in the office of Dy. Chief Engineer (S.W.D.) City. The Packet C shall be opened if bids submission in Packet A & B satisfies/includes all the requirements and same are found acceptable to the Authority.

The Municipal Commissioner reserves the right to reject all or any of the e- tender(s) without assigning any reasons at any stage.

The dates and time for submission and opening the bids are as shown in the Header Data. If there are any changes in the dates the same will be displayed on the MCGM Portal. (<http://portal.mcgm.gov.in>)

The Applicants interested for the above referred works may contact the Dy. Chief Engineer (S.W.D.) City at the following address on any working day during office hours.

Office of:

Deputy Chief Engineer (Storm Water Drains) City.
Engineering Hub Building,

Ground Floor,
Dr. E.Moses Road,
Worli Naka, Worli,
Mumbai- 400 018

The applicants may wish to visit the site under reference located near along Sion – Mahim link road in G/North ward **Mumbai** and can collect the information of the present status from the department who have invited the bid.

The MCGM reserves the rights to accept any of the application or reject any or all the applications received for above mentioned work, without assigning any reasons thereof. The information regarding above subject matter is available on Website of MCGM. (<http://portal.mcgm.gov.in/tenders>).

Sd/-

Dy. Ch.E. (S.W.D.) City.

HEADER DATA

Tender Document No.	7200027093
Name of Organization	Municipal Corporation of Greater Mumbai
Subject	CT-60 work of construction of RCC box drain of size 4m x 2m along Sion- Mahim link road from piwala Bunglow up to T-Junction in G/N ward.
Cost of Tender	Rs.11,092/- (Rs.9400/- + 9.0%CGST + 9.0% SGST).
Cost of E-Tender (Estimated Cost)	Rs. 33,99,12,418/-
Bid Security Deposit/EMD	Rs 33,99,200/-
Date of Issue and sale of Tender	03/02/2022 from 11:00 Hrs.
Pre bid meeting date	08/02/2022 at 15:00 Hrs.
Venue for Prebid meeting	Office of ChE (SWD)
Last date & time for sale of tender	17/02/2022 upto 16:00 Hrs.
Submission of Packet A, B & Packet C (Online) & Receipt of Bid Security Deposit /EMD	17/02/2022 upto 16:00 Hrs.
Opening of Packet A	17/02/2022 after 16.30 Hrs
Opening of Packet B	17/02/2022 after 16.40 Hrs
Opening of Packet C	25/02/2022 after 15:00 Hrs
Address for Communication	Office of : Deputy Chief Engineer (SWD) City, Engineering Hub Building, Dr. E.Moses Road, Worli Naka, Worli, Mumbai- 400 018.
Venue for opening of Bid	Online, in the office of Dy.Ch.E.(SWD)City.

This tender document is not transferable.

The MCGM reserves the rights to accept any of the application or reject any or all the application received for above subject without assigning any reason thereof.

Sd/-
Dy. Ch. E. (SWD) City

SECTION 2
ELIGIBILITY CRITERIA

1. For Regular, Routine and Maintenance works:

Not applicable to this tender.

2. For Original and New Construction Works :-

- (i) New SWD Pumping Stations & additional works, if any
- (ii) Construction of nallas at outfalls near creeks/sea.
- (iii) Construction of new pipe/RCC box drain with Micro-Tunneling methodology or any other special methodology as per site conditions.
- (iv) Rehabilitation / strengthening of existing storm water drain carried out with structural lining by trenchless technology (other than RCC lining).

2.1 Technical Capacity (Project Experience):

The tenderer(s) in their own name should have satisfactorily executed the work of similar nature MCGM /Semi Govt. /Govt. & Public Sector Organizations during last seven (7) years ending last day of month previous to the one in which bids are invited as a prime Contractor (or as a nominated sub-Contractor, where the subcontract had involved similar nature of work as described in the scope of works in this bid document, provided further that all other qualification criteria are satisfied)

- a) Three similar completed works or currently executing three works of similar nature each costing 30% of estimated cost.

OR

- b) Two similar completed works or currently executing two works of similar nature each costing 40% of estimated cost.

OR

- c) One completed work or currently executing one work of similar nature of aggregate 60% of estimated cost.

The value of executed works shall be brought to current costing level by enhancing the actual value of work at compound rate of 10 % per annum; calculated from the date of completion to last date of receipt of applications for tenders.

*In case of ongoing works to be considered, the bidder must have received payment bills of 80% of the contract sum for the work/works executed last day of month previous to the one in which bids are invited.

2.2 Financial Capacity

Achieved an average annual financial turnover as certified by 'Chartered Accountant' (in all classes of civil engineering construction works only) equal to 30% of the estimated cost of work in last three (3) financial years immediately preceding the Financial Year in which bids are invited.

- To ascertain this, tenderer(s) shall furnish /upload the financial statement (Audited balance sheet) duly certified by Chartered Accountant.
- The turnover can be enhanced by 10% every year to bring the present level.

2.3 Similar experience.

"Similar work shall mean, any work i.e. completed or currently executing works of construction of R.C.C. Box Drains.."

Note: This tender is classified as "Original and New Construction Works".

3. Bid Capacity:

The bid capacity of the prospective bidders will be calculated as under:

Assessed Available Bid Capacity = (A * N* 2 - B)

Where,

A = Maximum value of Civil Engineering works executed in any one year (year means Financial year) during the last five years (updated to the price level of the Financial year in which bids are received at a rate of 10% per year) taking into account the completed as well as works in progress.

N = Number of years prescribed for completion of the Project/Works, **excluding monsoon** period, for which these bids are being invited. (E.g. 9 months = 9/12 year) For every intervening monsoon 0.33 shall be added to N.

B = Value of existing commitments (only allotted works) on the last date of submission of bids as per bidding document and on-going works to be completed during the period of completion of the Project/Works for which these bids are being invited.

Note: The statement showing the value of existing commitments and on-going works as well as the stipulated period of completion remaining for each of the works listed should be attached along with certificates duly signed by the Engineer-in Charge, not below the rank of an Executive Engineer or equivalent.

Even though the bidders meet the above qualifying criteria, they are subject to be disqualified if they have:

- made misleading or false representation in the forms, statements and attachments submitted in proof of the qualification requirements; and/or
- Record for poor performance such as abandoning the works, not properly completing the contract, inordinate delays in completion, litigation history, or financial failures etc.

SECTION 3
DISCLAIMER

DISCLAIMER

The information contained in this e-tender document or provided to Applicant(s), whether verbally or in documentary or any other form, by or on behalf of the Municipal Corporation of Greater Mumbai (MCGM), hereafter also referred as “The Authority “, or any of its employees or advisors, is provided to Applicant(s) on the terms and conditions set out in this e-tender and such other terms and conditions subject to which such information is provided.

This e-tender includes statements, which reflect various assumptions and assessments arrived at by the Municipal Corporation of Greater Mumbai (MCGM) in relation to the Project. Such assumptions, assessments and statements do not purport to contain all the information that each Applicant may require. This e-tender may not be appropriate for all persons, and it is not possible for the Municipal Corporation of Greater Mumbai (MCGM), its employees or advisors to consider the investment objectives, financial situation and particular needs of each party who reads or uses this e-tender. The assumptions, assessments, statements and information contained in this e-tender may not be complete, accurate, adequate or correct. Each Applicant should therefore, conduct its own investigations and analysis and should check the accuracy, adequacy, correctness, reliability and completeness of the assumptions, assessments, statements and information contained in this e-tender and obtain independent advice from appropriate sources.

Information provided in this e-tender to the Applicant(s) is on a wide range of matters, some of which may depend upon interpretation of law. The information given is not intended to be an exhaustive account of statutory requirements and should not be regarded as a complete or authoritative statement of law. The Municipal Corporation of Greater Mumbai (MCGM) accepts no responsibility for the accuracy or otherwise for any interpretation or opinion on law expressed here.

The Municipal Corporation of Greater Mumbai(MCGM), its employees and advisors make no representation or warranty and shall have no liability to any person, including any Applicant or Bidder, under any law, statute, rules or regulations or tort, principles of restitution or unjust enrichment or otherwise for any loss, damages, cost or expense which may arise from or be incurred or suffered on account of anything contained in this e-tender or otherwise, including the accuracy, adequacy, correctness, completeness or reliability of the e-tender and any assessment, assumption, statement or information contained therein or deemed to form part of this e-tender or arising in any way with pre-qualification of Applicants for participation in the Bidding Process. The Municipal Corporation of Greater Mumbai (MCGM) also accepts no liability of any nature whether resulting from negligence or otherwise howsoever caused arising from reliance of any Applicant upon the statements contained in this e-tender.

The Municipal Corporation of Greater Mumbai (MCGM) may, in its absolute discretion but without being under any obligation to do so, update, amend or supplement the information, assessment or assumptions contained in this e-tender.

The issue of this e-tender does not imply that the Municipal Corporation of Greater Mumbai (MCGM) is bound to select and short-list pre-qualified Applications for Bid Stage or to appoint the selected Bidder or Concessionaire, as the case may be, for the Project and the Municipal Corporation of Greater Mumbai (MCGM) reserves the right to reject all or any of the Applications or Bids without assigning any reasons whatsoever.

The Applicant shall bear all its costs associated with or relating to the preparation and submission of its Application including but not limited to preparation, copying, postage, delivery fees, expenses associated with any demonstrations or presentations which may be required by The Municipal Corporation of Greater Mumbai (MCGM) or any other costs incurred in connection with or relating to its Application. All such costs and expenses will remain with the Applicant and the Municipal Corporation of Greater Mumbai(MCGM) shall not be liable in any manner whatsoever for the same or for any other costs or other expenses incurred by an Applicant in preparation or submission of the Application, regardless of the conduct or outcome of the Bidding Process.

SECTION 4
INTRODUCTION

INTRODUCTION

1. Background:

The Municipal Corporation of Greater Mumbai covers an area of 437.71sq.kms.with a population of 1.24 Crores as per census of 2011. The metropolis accounts major portion of India's international trade and government's revenue, from being one of the foremost centers of education, science and technological research and advancement.

The Mumbai Metropolis has historic tradition of strong civic activism dedicated to the cause of a better life for all its citizens. And it's the Municipal Corporation of Greater Mumbai (MCGM), hereafter called the "corporation", the primary agency responsible for urban governance in Greater Mumbai.

MCGM (The Authority) is one of the largest local self-governments in the Asian Continent. In observance of historic traditions of strong civic activism, with the change in time and living conditions to match with the urbanization, MCGM has mainly focused in providing almost all kinds of engineering services viz, Hydraulics, storm water drain, sewerage, water supply projects, roads, bridges, solid waste management, and environmental services. Beside this, the MCGM is also providing dedicated services in various segments such as Health, Primary Education as well as the construction and maintenance of Public Markets and Slaughter Houses.

MCGM is an organization having different departments, right from engineering depts. to health depts. Moreover we have other dept. like education, market, fire brigade dept., Octroi and other such departments where quite a good number of staff members are working.

Scope of Work:

MCGM is primarily an organization, which in the interest of citizens and with the speed of urbanization deals with the variety of the infrastructure services and delivered to the public by different departments like Water Supply Projects, Sewerage Projects, Hydraulics, Storm Water Drain/Roads and bridges and Building Construction etc.

Name of the Work: CT-60 work of construction of RCC box drain of size 4m x 2m along Sion- Mahim link road from piwala Bunglow up to T-Junction in G/N ward.

Scope of Work:-

Major works.

1. Construction of RCC Box drain of size 4m x 2m (For box drain construction, 50% work of slab by cast-in-situ methodology and 50% work of slab by precast methodology)
2. Reinstatement of road in C.C.

Estimated cost of the work: - Rs 33,99,12,418/-

Note:

- All the works contained in the scope of work shall be carried out strictly as per relevant specifications applicable as attached or referred to, in this tender document.
- The above is general description of the scope of work and actual work mentioned above shall be governed by B.O.Q. and as directed by the Engineer-in-Charge.
- Applicable schedules.- Unified schedule of rates with cognizance of GST for S.W.D., Building construction, Road works, Bridge works, Hydraulic Engineering, Sewerage Projects etc. **effective from 01.06. 2018**

SECTION 5
E-TENDERING ONLINE
SUBMISSION PROCESS

E-TENDERING ONLINE SUBMISSION PROCESS

The terminology of e-Tendering is solely depending upon policies in existence, guidelines and methodology adopted since decades. The SRM is only change in process of accepting and evaluation of tenders in addition to manual. The SAP module to be used in this E-tendering is known as Supplier Relationship Module (SRM).SRM is designed and introduced by ABM Knowledge ware Ltd. who will assist MCGM in throughout the tendering process for successful implementation.

NOTE: This tendering process is covered under Information Technology ACT & Cyber Laws as applicable

(1) In e-tendering process some of the terms and its definitions are to be read as under wherever it reflects in online tendering process.

Start Date read as “Sale Date”

End Date read as “Submission Date”

Supplier read as “Contractor/bidder”

Vendor read as “Contractor/bidder”

Vendor Quotation read as “Contractors Bid/Offer”

Purchaser read as “Department/MCGM”

- I. Before entering in to online tendering process, the contractors should complete the registration process so as to get User ID for E-tendering links. For this, the contractors can access through Supplier registration via MCGM Portal.

There are two methods for this registration :(II and III)

- II. Transfer from R3 (registered contractors with MCGM) to SRM
 - a) Contractors already registered with MCGM will approach to Vendor Transfer cell.
 - b) Submit his details such as (name, vendor code, address, registered Email ID, pan card etc.) to Vendor transfer cell.
 - c) MCGM authority for Vendor Transfer, transfers the Vendor to SRM application from R3 system to SRM system.
 - d) Transferred Vendor receives User ID creation link on his supplied mail Id.
 - e) Vendor creates his User ID and Password for e-tendering applications by accessing link sent to his mail ID.
- III. Online Self Registration (Temporary registration for applicant not registered with MCGM)

- a) Vendor fills up Self Registration form via accessing MCGM portal.
- b) Vendor Transfer cell (same as mentioned above) accesses Supplier Registration system and accepts the Vendor request.
- c) Accepted Vendor receives User ID creation email with Link on his supplied mail Id.
- d) Vendor creates his User ID and Password for e-tendering application.

IV. CONTRACTORS BIDDING: Applicant will Quote and Upload Tender Documents:

- 1) Access e-tender link of SRM Portal
- 2) Log in with User ID and Password
- 3) Selects desired Bid Invitation (he wants to bid)
- 4) To download tender documents contractors will have to pay online Tender fee. The same can be done by accessing Pay Tender Fees option. By this one will be able to pay Tender fee through Payment Gateway-If transaction successful, Contractors can register his interest to participate. Without Registration one cannot quote for the Bid/Tender.
- 5) Applicant will download Tender Documents from Information from purchaser tab by accessing Purchaser document folder through collaboration 'C' folder link.
- 6) Applicant will upload Packet A related, Packet B related and Packet C related Documents in Packet A, Packet B and C folder respectively by accessing these folders through "My Notes" Tab and collaboration folder link.
- 7) All the documents uploaded have to be digitally signed and saved. Contractors can procure there digital signature from any certified CA's in India.
- 8) Bid security deposit/EMD, if applicable, should be paid online and ASD, if applicable, should be paid offline as mentioned in tender.
- 9) For commercial details (in Packet C) contractors will fill data in Item Data tab in Service Line Item via details and quotes his "Percentage Variation" (i.e.% quoted) figure.(If entered '0' it will be treated as at par. By default the value is zero only.
- 10) Applicants to check the bid, digitally signs & save and submit his Bid Invitation.
- 11) Applicants can also save his uploaded documents/commercial information without submitting the BID for future editing through 'HOLD' option.
- 12) Please note that "Hold" action do not submit the Bid.
- 13) Applicants will receive confirmation once the Bid is submitted.
- 14) Bid creator (MCGM) starts Bid Opening for Packet A after reaching End Date and Time and Bid Evaluation process starts.

As per Three Packet system, the document for Packet A & B are to be uploaded by the tenderer in 'Vendor's document' online in Packet A & B. Before purchasing/ downloading the tender copy, tenderer may refer to post- Qualification criteria mentioned in e-Tender Notice.

The tenderer shall pay the EMD/Bid Security through payment gateways before submission of Bid and shall upload the screenshot of receipt of payment in Packet 'A' instead of paying the EMD at any of the CFC centers in MCGM Ward Offices.

The e-tender is available on MCGM portal, <http://portal.mcgm.gov.in>, as mentioned in the Header Data of the tender. The tenders duly filled in should be uploaded and submitted online on or before the end date of submission. The Packet 'A', Packet 'B' & Packet 'C' of the tenderer will be opened as per the time-table shown in the Header Data in the office of **Dy.Ch. Eng.(S.W.D.)City**.

The Municipal Commissioner reserves the right to reject all or any of the e-Tender(s) without assigning any reason at any stage. The dates and time for submission and opening the tenders are as shown in the Header Data. If there are any changes in the dates the same will be displayed on the MCGM Portal (<http://portal.mcgm.gov.in>).

SECTION 6
INSTRUCTIONS TO
APPLICANTS

INSTRUCTIONS TO APPLICANTS

➤ **Scope of Application**

The Authority wishes to receive Applications for Qualification in order to SELECT experienced and capable Applicants for the Bid Stage.

➤ **Eligibility of Applicants**

The Municipal Corporation of Greater Mumbai (MCGM) invites e-tender to appoint Contractor for the aforementioned work from contractors of repute, multidisciplinary engineering organizations i.e. eminent firm, Proprietary/Partnership Firms/ Private Limited Companies/ Public Limited Companies/Companies registered under the Indian companies' act 2013, the contractors registered with the Municipal Corporation of Greater Mumbai, (MCGM) in **Class I(A) as per new registration policy 2015 & 2016** and from the contractors/firms equivalent and superior classes registered in Central or State Government/Semi Govt. Organization/Central or State Public Sector Undertakings, will be allowed subject to condition that, the contractors who are not registered with MCGM will have to apply for registering their firm within three months' time period from the award of contract, otherwise their Bid Security i.e. E.M.D (Earnest Money Deposit) will be forfeited/recovered and a penalty of 0.1% of contract cost or Rs 10,000/- whichever is more will be recovered/deducted from the contractors payment/bill by the executing department in MCGM.

To be eligible for pre-qualification and short-listing, an Applicant shall fulfill the following conditions of eligibility:

A. For Regular, Routine and Maintenance works:

Not applicable to this tender.

B. For Original and New Construction Works :-

- (i) New SWD Pumping Stations & additional works, if any
- (ii) Construction of nallas at outfalls near creeks/sea.
- (iii) Construction of new pipe/RCC box drain with Micro-Tunneling methodology or any other special methodology as per site conditions.
- (iv) Rehabilitation / strengthening of existing storm water drain carried out with structural lining by trenchless technology (other than RCC lining).

2.1 Technical Capacity (Project Experience):

The tenderer(s) in their own name should have satisfactorily executed the work of similar nature MCGM /Semi Govt. /Govt. & Public Sector Organizations during last seven (7) years ending last day of month previous to the one in which bids are invited as a prime Contractor (or as a nominated sub-Contractor, where the subcontract had involved similar nature of work as described in the scope of works in this bid document, provided further that all other qualification criteria are satisfied)

- a) Three similar completed works or currently executing three works of similar nature each costing 30% of estimated cost.

OR

- b) Two similar completed works or currently executing two works of similar nature each costing 40% of estimated cost.

OR

- c) One completed work or currently executing one work of similar nature of aggregate 60% of estimated cost.

The value of executed works shall be brought to current costing level by enhancing the actual value of work at compound rate of 10 % per annum; calculated from the date of completion to last date of receipt of applications for tenders.

*In case of ongoing works to be considered, the bidder must have received payment bills of 80% of the contract sum for the work/works executed last day of month previous to the one in which bids are invited.

2.2 Financial Capacity

Achieved an average annual financial turnover as certified by 'Chartered Accountant' (in all classes of civil engineering construction works only) equal to 30% of the estimated cost of work in last three (3) financial years immediately preceding the Financial Year in which bids are invited.

- To ascertain this, tenderer(s) shall furnish /upload the financial statement (Audited balance sheet) duly certified by Chartered Accountant.
- The turnover can be enhanced by 10% every year to bring the present level

2.3 Similar experience.

“Similar work shall mean, any work i.e. completed or currently executing works of construction of R.C.C. Box Drains.”

Note: This tender is classified as “Original and New Construction Works”.

C. Bid Capacity:

The bid capacity of the prospective bidders will be calculated as under:

Assessed Available Bid Capacity = (A* N* 2 - B)

Where,

A = Maximum value of Civil Engineering works executed in any one year (year means Financial year) during the last five years (updated to the price level of the Financial year in which bids are received at a rate of 10% per year) taking into account the completed as well as works in progress.

N = Number of years prescribed for completion of the Project/Works, **excluding monsoon** period, for which these bids are being invited. (E.g. 9 months = 9/12 year) For every intervening monsoon 0.33 shall be added to N.

B = Value of existing commitments (only allotted works) on the last date of submission of bids as per bidding document and on-going works to be completed during the period of completion of the Project/Works for which these bids are being invited.

Note: The statement showing the value of existing commitments and on-going works as well as the stipulated period of completion remaining for each of the works listed should be attached along with certificates duly signed by the Engineer-in Charge, not below the rank of an Executive Engineer or equivalent.

Even though the bidders meet the above qualifying criteria, they are subject to be disqualified if they have:

- made misleading or false representation in the forms, statements and attachments submitted in proof of the qualification requirements; and/or
- Record for poor performance such as abandoning the works, not properly completing the contract, inordinate delays in completion, litigation history, or financial failures etc

D) Equipment Capabilities as required for this work

- a) **Regular and Routine works:** The successful bidder will make the arrangements of the required equipment on the day of commencement or with respect to the progress of the work in phases, as per the instructions of site in charge. The successful bidder and, to that effect he will ensure commitment on **an undertaking on Rs.500/- stamp paper** to be submitted along with the Bid in Packet B. However, this condition in no way shall dilute the respective condition in Registration Rules of MCGM.
- b) **New and Original Works:** The bidder should, undertake their own studies and furnish with their bid, a detailed construction planning and methodology supported with assessment study of requirements of equipment/plants & machineries to allow the employer to review their proposal. The bidder will ensure his commitment to make the arrangements of the required equipment on the day of commencement or with respect to the progress of the work in phases, as per the instructions of site in charge on an undertaking on Rs.500 stamp paper to be submitted along with the Bid in Packet B. However, this condition in no way shall dilute the respective condition in Registration Rules of MCGM.
- c) **Special Works:** The concerned Ch.Eng. shall enlist the equipment's in the tender document justified for the project and ensure the capacity of the bidder for the same with the approval of concerned AMC.

Note: Bidders shall submit the undertaking for equipment capability and other undertakings as such on a single Rs. 500/- stamp paper.

E) Technical Personnel

The contractor and/or its managerial staff should have qualification/experience appropriate to the function they fulfill. The minimum standard shall be increased by asking that at least one number or more of the contractor or its managerial staff have acquired qualifications or work experience to the needs of the contract. The minimum standard may also state that the person or persons responsible for managing the works must have a minimum of no's of years' experience working on similar nature of projects.

For fixing requirement of Technical Staff as required for this work.

(A) General Guidelines for Fixing Requirement of Technical Staff

Cost of Work (Rs. In Crore)	Requirement of Technical Staff (Major+Minor Component)		Minimum Experience (years)	Designation
	Qualification	Number		
More than 100	i) Graduate Engineer (Major Component)	1	20	Project Manager in Major Discipline of Engineering
	ii) Graduate Engineer	2+1	12	Deputy Project Manager in Major Discipline of Engineering
	iii) Graduate Engineer or Diploma Engineer	4	5	Project/Site Engineer
		2	10	
	iv) Graduate Engineer	1+1	8	Quality Engineer
	v) Diploma Engineer	1	8	Surveyor
	vi) Graduate Engineer	1+1	6	Project Planning /Billing Engineer
More than 50 to 100	i) Graduate Engineer	1	20	Project Manager
	ii) Graduate Engineer	1+1	12	Deputy Project Manager
	iii) Graduate Engineer or Diploma Engineer	2+1	5 or 10	Project/Site Engineer
		1	8	
	iv) Graduate Engineer	1	8	Quality Engineer
	v) Diploma Engineer	1	8	Surveyor
	vi) Graduate Engineer	1+1	6	Project Planning /Billing Engineer
More than 20 to 50	i) Graduate Engineer	1	20	Project Manager

	ii) Graduate Engineer or Diploma Engineer	1+1	5 or 10	Project/Site Engineer
	iii) Graduate Engineer	1	8	Quality Engineer
	iv) Diploma Engineer	1	8	Surveyor
	v) Graduate Engineer	1+1	6	Project Planning /Billing Engineer

Notes:-

- 1) "Cost of work", in table above, shall mean the agreement amount of the work.
- 2) Rate of recovery in case of non-compliance of the clause be stipulated at following rates:-

Sr. No.	Qualification	Experience (Years)	Rate of Recovery
1	Project Manager with Degree	20	Rs.60000/- p.m.
2	Deputy Project Manager with Degree	12	Rs.40000/- p.m.
3	Project/Site Engineer (Degree/Diploma)	5 or 10 respectively	Rs.25000/- p.m.
4	Quality Graduate Engineer	8	Rs.25000/- p.m.
5	Surveyor	8	Rs.15000/- p.m.
6	Project Planning /Billing Engineer	6	Rs.20000/- p.m.

- 3) Nothing extra need to be added while preparing market rate justified amount of the work if stipulation is made as per above recommended scale of technical staff.
- 4) Requirement of technical staff and their experience can be varied depending upon cost and complexity of the work by competent authority i.e. Chief Engineer with recorded reasons.
- 5) The failure in providing experienced technical and /professional ability personnel and even ignoring the instruction of the Engineer-in-charge shall be linked to penalization. Such disobeying attitude of the contractor shall also be reported to Vigilance/Registration & Monitoring department.

(B) General Guidelines for Fixing Requirement of Technical Staff

Cost of Work (Rs. In Crore)	Requirement of Technical Staff (Major+Minor Component)		Minimum Experience (years)	Designation
	Qualification	Number		

10 to 20	i) Project Manager with degree in corresponding discipline of Engineering	1	10	Principle Technical Representative
	ii) Graduate Engineer	1	5	Technical Representative
	iii) Graduate Engineer or Diploma Engineer	2	2	Project/Site Engineer and Project Planning /Billing Engineer.
		2	5	
More than 5 to 10	i) Graduate Engineer	1	5	Principle Technical Representative
	ii) Graduate Engineer or Diploma Engineer	2	2	Project/Site Engineer.
		2	5	Billing Engineer
More than 1.5 to 5	i) Graduate Engineer	1	5	Principle Technical Representative
	ii) Graduate Engineer or Diploma Engineer	2	2	Project/Site Engineer.
		2	5	Billing Engineer
Upto 1.5	ii) Graduate Engineer or Diploma Engineer	1	2	Principle Technical Representative
		1	5	Project/Site Engineer/ Billing Engineer

Notes-

- 1) "Cost of work", in table above, shall mean the agreement amount of the work.
- 2) Rate of recovery in case of non-compliance of the clause be stipulated at following rates:-

Sr. No.	Qualification	Experience (Years)	Rate of Recovery
1	Project Manager with Degree	10	Rs.30000/- p.m.
2	Graduate Engineer	5	Rs.25000/- p.m.
3	Graduate Engineer	2	Rs.15000/- p.m.
4	Diploma Engineer	5	Rs.15000/- p.m.

- 3) Nothing extra need to be added while preparing market rate justified amount of the work if stipulation is made as per above recommended scale of technical staff.
- 4) Requirement of technical staff and their experience can be varied depending upon cost and complexity of the work by competent authority i.e. Chief Engineer with recorded reasons.

F. **TIME PERIOD OF THE PROJECT:**

Entire project should be completed and delivered within 6 months (excluding monsoon) of time from the date of award of contract that excludes Monsoon. The time allowed for carrying out the work as entered in the Tender shall be strictly observed by the Contractor and shall be reckoned from the date on which the contract is awarded to the Contractor. The work shall throughout the stipulated period of the Contract be proceeded with all due diligence as time being deemed to be the essence of the contract on the part of the Contractor. On failing to do so, the Contractor shall pay as compensation an amount which shall be governed as per Clause - 8(e) of Standard General Conditions of Contract.

The Contractor should complete the work as per phase given below :

¼ of the work in	..	2/5 of the time
2/5 of the work in	..	½ of the time
3/5 of the work in	..	¾ of the time
Full work	..	Full time

Full work will be completed in **6 months excluding monsoon.**

The programme for completion of work shall be a part of the Contract Document in the form of Bar Chart / GANTT Chart. The Contractor is supposed to carry out the work and keep the progress as per Bar Chart/GANTT Chart. The Contractor shall complete the work as per the Schedule given in the Contract and the programme submitted by the Contractor.

G. **Contract Execution**

All required documents for execution of the contract shall be submitted within 30 days from the date of issue of letter of acceptance. If the documents are not submitted within the stipulated time, a penalty of Rs 5000/- per day will be applicable to the contractor. All contract documents need to be duly affixed with stamp duty properly signed along with evidence/proof of payment of security/contract deposit/ within 30 days from the date of letter of acceptance received by him.

H. If the amount of the Contract Deposit to be paid above is not paid within 30 days from the date of issue of Letter of Acceptance, the Tender / Contractor already accepted shall be considered as cancelled and legal steps be taken against the contractor for recovery of the amounts.

I. The amount of Security Deposit retained by the MCGM shall be released after expiry of period up to which the contractor has agreed to maintain the work in good order is over. In the event of the contractor failing or neglecting to complete the rectification work within the period up to which the contractor has agreed to maintain the work in good order, the amount of security deposit retained by MCGM shall be adjusted to- wards the excess cost incurred by the Department on rectification work.

J. **Action when whole of security deposit is forfeited:**

In any case in which under any Clause of this contract, the contractor shall have rendered himself liable to pay compensation amounting to the whole of this security deposit whether paid in one sum or deducted by installments or in the case of abandonment of the work owing to serious illness or death of the contractor or any other cause, the Engineer on behalf of the Municipal Commissioner shall have power to adopt any of the following process, as he may deem best suited to the interest of MCGM –

- a) To rescind the contract (for which recession notice in writing to the contractor under the head of Executive Engineer shall be conclusive evidence) and in that case, the security deposit of the contract shall stand forfeited and be absolutely at the disposal of MCGM.
- b) To carry out the work or any part of the work departmentally debiting the contractor with the cost of the work, expenditure incurred on tools and plant, and charges on additional supervisory staff including the cost of work- charged establishment employed for getting the un-executed part of the work completed and crediting him with the value of the work done departmentally in all respects in the same manner and at the same rates as if it had been carried out by the contractor under the terms of his contract. The certificate of the Executive Engineer as to the costs and other allied expenses so incurred and as to the value of the work so done departmentally shall be final and conclusive against the contractor.
- c) To order that the work of the contractor be measured up and to take such part thereof as shall be un-executed out of his hands, and to give it to another contractor to complete, in which case all expenses incurred on advertisement for fixing a new contracting agency, additional supervisory staff including the cost of work charged establishment and the cost of the work executed by the new contract agency will be debited to the contractor and the value of the work done or executed through the new contractor shall be credited to the contractor in all respects and in the same manner and at the same rates as if it had been carried out by the contractor under the terms of his contract. The certificate of the Executive Engineer as to all the cost of the work and other expenses incurred as aforesaid

for or in getting the un-executed work done by the new contractor and as to the value of the work so done shall be final and conclusive against the contractor.

- d) In case the contract shall be rescinded under Clause (a) above, the contractor shall not be entitled to recover or be paid any sum for any work therefore actually performed by him under this contract unless and until the Executive Engineer shall have certified in writing the performance of such work and the amount payable to him in respect thereof and he shall only be entitled to be paid the amount so certified. In the event of either of the courses referred to in Clause (b) or (c) being adopted and the cost of the work executed departmentally or through a new contractor and other allied expenses exceeding the value of such work credited to the contractors amount of excess shall be deducted from any money due to the contractor, by MCGM under the contract or otherwise, howsoever, or from his security deposit or the sale proceeds thereof provided, however, the contractor shall have no claim against MCGM even if the certified value of the work done departmentally or through a new contractor exceeds the certified cost of such work and allied expenses, provided always that whichever of the three courses mentioned in clauses (a), (b) or (c) is adopted by the Executive Engineer, the contractor shall have no claim to compensation for any loss sustained by him by reason of his having purchase or procured any materials or entered in to any engagements or made any advance on account of or with a view to the execution of the work or the performance of the contract.

K. Contract may be rescinded and security deposit forfeited for bribing a public officer or if contractor becomes insolvent

If the contractor assigns or sublets his contracts or attempt so to do, or become insolvent or commence any proceeding to get himself adjudicated and insolvent or make any composition with his creditors, or attempt so to do or if bribe, gratuity, gift, loan, perquisite, reward or advantage, pecuniary or otherwise, shall either directly or indirectly be given promised or offered by the contractor or any of his servants or agents through any public officer, or person in the employ of MCGM/Govt. in any way relating to his office or employment, or if any such officer or person shall become in any way directly or indirectly interested in the contract the Engineer In-charge may thereupon, by notice in writing rescind the contract and the Security Deposit of the Contractor shall thereupon stand forfeited and be absolutely at the disposal of MCGM and the same consequences shall ensure as if the contract had been rescinded under above clause J hereof; and in addition the contractor shall not be entitled to recover or be paid for any work therefore actually performed under the contract.

Classes available according to the limits of works, amount of solvency, Registration fees and amount of standing deposit prescribed for each class.

Class	Works Limit	Solvency Amount	Serutiny Fees	Registration Fees	Renewal Fees
	Rs.	(Rs. in Lakhs)	Rs.	Rs.	Rs.
AA	Without limit	60	4000	8000	4000
A	Up to 3 Crores	30	4000	8000	4000
B	Up to 1 Crore	20	2000	4000	2000
C	Up to 50 Lakhs	15	2000	4000	2000
D	Up to 25 Lakhs	10	2000	4000	2000
E	Up to 10 Lakhs	5	2000	4000	2000

Classes available for Civil Engineering works according to the limits of works, amount of solvency, Registration fees and amount of standing deposit prescribed for each class. (As per the reframed rules circulated under number EE/M&R/517/Civil, dated 26.05.2015)

MUNICIPAL CORPORATION OF GREATER MUMBAI

NOTICE

SUB: "RULES GOVERNING THE REGISTRATION OF CONTRACTOR/S FOR CIVIL AND MECHANICAL & ELECTRICAL ENGINEERING WORKS – 2016".

All are requested to note that the existing rules for the registration of contractor/s are now reframed and the New Rules-2016 titled, "RULES GOVERNING THE REGISTRATION OF CONTRACTOR/S FOR CIVIL AND MECHANICAL & ELECTRICAL ENGINEERING WORKS – 2016" are made effective from 01/12/2016.

Therefore, henceforth no new registration will be done except under the New Rules of 2016.

Booklet of the new registration rules and application form will be available from Executive Engineer (Monitoring & Registration) Cell's office, provisionally from 5th December 2016 onwards on payment of prescribed charges amounting Rs.1,000/-+VAT each for booklet and application form separately.

At present, there are few contractors who are registered as per Registration Rules 1992 & Registration Rules 2015. Even after implementation of Registration Rules 2016, all these contractors registered earlier will also be allowed to participate in bidding procedure of MCGM, till the expiry of validity of their registration. Thereafter they have to get registered as per Registration Rules 2016 only. If desired they may apply for registration as per Registration Rules 2016, even before expiry of their existing registration.

Registration as per rules 1992 will be phased out completely in Dec 2017 and registrations as per rules 2015 will be phased out completely in December 2019. Thereafter, tenders will be invited from the contractors registered as per rules 2016 only and any contractor, whether Civil or M&E, who is not registered as per the new rules, will not be eligible to participate in the bidding procedure of MCGM.

For further details please visit Tender / Manual on MCGM portal on <http://portal.mcgm.gov.in>

sd/-

City Engineer

sd/-

C.A. (Finance)

sd/-

Director (E. S. & P.)

Table – I
MINIMUM FINANCIAL REQUIREMENTS FOR CIVIL ENGINEERING DISCIPLINE

(Rs. In Lakhs)

Class	Amounts upto which works can be taken up	Minimum Solvency	Average turnover of work done during last 3 years	Estimated cost of work in hand during current year
I(A)	Without Limit 2500 1500	150	300	450
I(B)				
I(C)				
II	750	75	200	300
III	300	30	90	150
IV	150	15	60	80
IV(A)	90	9	40	60
V	50	5	25	30
V(A)	30	3	15	10
VI	15	2	7.5	10
VII	7	1	1.5	3
VIII	3	0.50	1	1.5
IX	2	0.25	0.5	1

Note: -

- 1) A Solvency Certificate shall not be accepted for the purpose of registration / renewal / up-gradation more than 12 months after the date on which it was granted. Certificate of Solvency (in Hindi / Marathi /English) shall be obtained from scheduled or Nationalised Bank, in the name of the applicant / Firm / Company only.
- 2) Turn-over shall be supported with work completion / performance certificate of Civil / M&E works only. In case of works carried out in Private Organization; T.D.S. Certificate (Form No.16/ 26AS) is essential and certificate from Licensed Architect and Chartered Accountant is necessary.
- 3) Respective amounts mentioned against class shows upper tendering limit of that class, however number of works can be carried out simultaneously will be governed by the bid capacity of the contractor/s.
- 4) The application for New Registration shall be considered only if the contractor has carried out / is carrying out **at least two sizable works** where the value of work done is in each case is not less than the maximum limits of the category two stages below the category for which he has applied (e.g. Category – III for registration in Category – I and category IV for registration in category II and so on). The weightage shall be given for works carried out for private persons / bodies shall be 100% of the value of work as certified by the Registered Chartered Accountant or Registered income Tax Practitioner (Format X).

SUBMISSION OF TENDERS

PACKET-A

The Packet 'A' shall contain scanned certified copies of the following Original documents-

Scrutiny of this packet will be done strictly with reference to only the scanned copies of **Original documents** uploaded online in packet 'A'

- a) Valid Registration Certificate.
- b) Valid Bank Solvency Certificate of Minimum Solvency amount as governed by Registration Rules in force for respective Class of Contractor for Civil and M&E works.
- c) A document in support of Registration under GST Act 2017. Those who have not registered shall submit an undertaking to the effect that if they become successful tenderer, they shall submit GST Certificate in Maharashtra within 15 days of issue of work order, failing which payment for the work executed will not be released.
- d) Certified copies of valid 'PAN' documents and photographs of the individuals, owners, Karta of Hindu undivided Family, firms, private limited companies, registered co-operative societies, partners of partnership firms and at least two Directors, if number of Directors are more than two in case of Private Limited Companies, as the case may be. However, in case of Public Limited companies, Semi Government Undertakings, Government Undertakings, no 'PAN' documents will be insisted.
- e) Latest Partnership Deed in case of Partnership firm duly registered with Chief Accountant (Treasury) of MCGM and registration certificate with registrar of companies in case of Private Ltd/Public Ltd/Semi Govt & Govt undertakings.
- f) The bidders shall categorically provide their Email-ID in packet 'A'.
- g) Scanned copy of details of online payment of EMD shall be uploaded.

NOTE:

- If the tenderer(s) withdraw tender offer during the tender validity period, his entire E.M.D shall be forfeited.
- If it is found that the tenderer has not submitted required documents in Packet "A" then, the shortfalls will be communicated to the tenderer through e-mail only and compliance required to be made within a time period of **three working days** otherwise they will be treated as non-responsive.

PACKET – B

The Packet ‘B’ shall contain scanned certified copies of the following Original documents –

- a)** The list of similar type of works as stated in para ‘A’ of Post qualification successfully completed during the last seven years in prescribed proforma, in the role of prime contractor. Information furnished in the prescribed proforma (**Proforma – I**) shall be supported by the certificate duly self-attested. Documents stating that it has successfully completed during the last seven years at least one contract of similar works as stated in para ‘A’ of Post qualification.
- b)** Annual financial turnover for **preceding 3 (three) financial years as certified by Chartered Accountant** preceding the Financial Year in which bids are invited. **Copies of Applicants duly audited balance sheet and profit and loss account for the preceding three financial years preceding the Financial Year in which bids are invited. (Proforma – II)**
- c)** Documents stating that, it has access to or has available liquid assets, unencumbered assets, lines of credit and other financial means (independent of any contractual advance payment) sufficient to meet the construction cash flow requirements for the subject contract in the event of stoppage, start-up, or other delay in payment, of the minimum 15% of the cost of the work tendered for, net of the tenderer's commitment of other contracts (Certificate from Bankers / C.A./Financial Institution shall be accepted as a evidence).
- d)** The bidder shall give undertaking on Rs 500/-stamp paper that it is his/their sole responsibility to arrange the required machineries either owned/on lease or hire basis, at site before start of the work
 - I. Regular and Routine works:** Not applicable to this bid.
 - II. New and Original Works:** The successful bidder shall make the arrangements of the required equipment on the day of commencement or with respect to the progress of the work in phases, as per the instructions of site in charge. The successful bidder and, to that effect he will ensure commitment on an undertaking on Rs.500 stamp paper to be submitted along with the Bid in Packet B. However, this condition in no way shall dilute the respective condition in Registration Rules of MCGM.
 - III. Special Works:** Not applicable to this bid.

- e) Details of works in hand (Proforma VI-A & VI-B) (original), along with copies of work orders & attested copies of percentage of works completed or part thereof.
- f) Statement showing assessed available Bid Capacity.
- g) The undertaking of Rs.500/- stamp paper as per the proforma annexed in ‘Annexure B & C’

Note: Bidders shall submit the undertaking for equipment capability and other undertakings as such on a single Rs.500/- stamp paper.

- h) The tenderers shall upload work plan as per the following outline:

- 1) GANTT chart/ PERT/ CPM chart showing the completion of work within prescribed time period, considering major activities.
- 2) Organizational set up envisaged by the contractors.
- 3) Plant & equipment proposed to be deployed for this work.
- 4) Site Offices and Laboratories proposed to be setup.
- 5) A note on how the whole work will be carried out (work plan including methodology).
- 6) Quality management plan.
- 7) All the activities included in the Scope of Work shall be covered in the work plan.
- 8) Corrigendum /Addendum, if any.
- 9) Details of Litigation History as per circular no .MGC/F/6565 dated 25.09.2018 (Proforma VIII) in which the tenderer is involved – Proforma as below

Other Party/Parties	Employer	Cause of Dispute	Amount involved.	Remarks showing Present Status.
1	2	3	4	5

Note:

- i. The Electrical / Mechanical work shall be got carried out by the civil contractors through the contractors registered with MCGM. in Electrical Category. Information about the registered contractors shall be obtained from the office of the Ch.E. (M&E)/ E.E. (Monitoring & Registration Cell). Attested scanned copy of the valid registration certificate in Electrical Category shall be uploaded with the tender along with the undertaking from the registered Electrical Contractor stating his willingness to carry out the tenderwork.
- ii. The successful bidder shall submit valid registration certificate under E.S.I.C., Act 1948,

if the tenderer has more than 10 employees /persons on his establishment (in case of production by use of energy) and 20 employees/persons on his establishment (in case of production without use of energy) to MCGM as and when demanded. In case of less employees/persons mentioned above then the successful bidder has to submit an undertaking to that effect on Rs. 500 stamp paper as per circular u/no. CA/FRD/I/65 of 30.03.2013.

- iii. The successful bidder shall submit valid registration certificate under E.P.F. &M.P., Act 1952, if tenderer has more than 20 employees/persons on his establishment, to MCGM as and when demanded. In case if the successful bidder has less employees/persons mentioned above then the successful bidder has to submit an undertaking to that effect on Rs. 500 stamp paper as per circular u/no. CA/FRD/I/44 of 04.01.2013.

Note: If it is found that the tenderer has not submitted required documents in Packet “B” then, the shortfalls will be communicated to the tenderer through e-mail only and compliance required to be made within a time period of three working days otherwise they will be treated as non-responsive.

PACKET – C

- a) Online tender filled in either percentage plus or minus (above or below), or at par. (There is no separate provision to quote % in physical form, this is a part in Header Data of online Tendering). For Packet ‘C’ tenderer (s) will fill data in ‘Item Data Tab’ in Service Line Item via Details and quotes his percentage variation figures. **(If entered ‘0’ it will be treated as ‘at par’.** By default the value is zero only).

Note: In case of rebate/premium of 15% and above as quoted by the tenderer, the rate analysis of major items of the bid shall be submitted by L1 and L2 bidder after demand notification by e-mail to bidders by concerned Dy. Ch Eng (S.W.D.) City. The format for rate analysis is annexed at Annexure D.

Rate Analysis in prescribed format shall be submitted via e-mail/online within 3 working days from the date of communication on email to submit rate analysis, failing which 10% EMD will be forfeited. If rate analysis submitted by bidder is found unjustified, offer will be treated as non responsive and 10% EMD will be forfeited.

BID SECURITY OR EMD

- The Bidder shall furnish, as part of the Bid, Bid Security/EMD, in the amount specified in the Bid Data Sheet. This bid security shall be in favor of the authority mentioned in the Bid Data Sheet and shall be valid till the validity of the bid.
- The tenderers shall pay the EMD online instead paying the EMD at any of the CFC center in MCGM Ward Offices.
- Any bid not accompanied by an acceptable Bid Security and not secured as indicated in sub-clause mentioned above, shall be rejected by the Employer as non-responsive.
- The Bid Security of the successful Bidder will be discharged when the Bidder has signed the Agreement and furnished the required Security Deposits.
- The Bid Security/ EMD of L-2 and downward bidder shall be refunded immediately after opening of financial bid. ~~but, the EMD/ASD submitted by the L-2 bidder will be returned after obtaining Standing Committee Resolution.~~
- **The Bid Security may be forfeited:**
 - a) If the Bidder withdraws the Bid after bid opening (opening of technical qualification part of the bid during the period of Bid validity;
 - b) In the case of a successful Bidder, if the Bidder fails within the specified time limit to:
 - i. sign the Agreement; and/or
 - ii. Furnish the required Security Deposits.
 1. The cases wherein if the shortfalls are not complied by a contractor, will be informed to Registration and Monitoring Cell. Such non-submission of documents will be considered as 'Intentional Avoidance' and if three or more cases in 12 months are re-ported, shall be viewed seriously and disciplinary action against the defaulters such as banning/de-registration, etc. shall be taken by the registration cell with due approval of the concerned AMC.
 2. No rejections and forfeiture shall be done in case of curable defects. For non-curable defects the 10% of EMD shall be forfeited and bid will be liable for rejection.

Note:

I. Curable Defect shall mean shortfalls in submission suchas:

- a. **Non-submission of following documents,**
 - i. **Valid Registration Certificate.**
 - ii. **Valid Bank Solvency.**
 - iii. **GST 2017 registration certificate.**
 - iv. **Certified Copies of PAN documents and photographs of individuals, owners,**

etc.

v. **Partnership Deed and any other documents.**

vi. **Undertakings as mentioned in the tender document.**

II. Non-curable Defect shall mean

- a) **In-adequate submission of EMD/ASD amount,**
- b) **In-adequacy of technical and financial capacity with respect to Eligibility criteria as stipulated in the tender.**
- c) **Non-Submission of Rate Analysis within three days of opening of Packet-C.**
- d) **Wrong calculation of Bid Capacity.**
- e) **No proper submission of experience certificates and other documents, etc.**

BID VALIDITY

- Bids shall remain valid for a period of not less than one eighty (**180**) days after the deadline date for bid submission specified in Bid Data Sheet. A bid valid for a shorter period shall be rejected by the Employer as non-responsive.
- In exceptional circumstances, prior to expiry of the original time limit, the Employer may request that the bidders may extend the period of validity for a specified additional period. The request and the bidders' responses shall be made in writing or by cable. A bidder may refuse the request without forfeiting his Bid Security. A bidder agreeing to the request will not be required or permitted to modify his bid, but will be required to extend the validity of his bid security for a period of the extension.

DEFECT LIABILITY PERIOD

- The Contractor is expected to carry out the construction work in workmen like manner so as to meet the requirement and specification for the project. It is expected that the workmanship and materials will be reasonably fit for the purpose for which they are required.
- Defects or defective work is where standard and quality of workmanship and materials as specified in the contract is deficient. Defect is defined as a failure of the completed project to satisfy the express or implied quality or quantity obligations of the construction contract. Defective construction works are as the works which fail short of complying with the express descriptions or requirements of the contract, especially any drawings or specifications with any implied terms and conditions as to its quality, workmanship, durability, aesthetic, performance or design. Defects in construction projects are attributable to various reasons.
- Some of the defects are structural defects results in cracks or collapse of faulty defective plumbing,

inadequate or faulty drainage system, inadequate or faulty ventilation, cooling or heating systems, inadequate fire systems etc. The defects could be various on accounts of different reasons for variety of the projects.

- The Engineer-in-charge/ Project Officer shall issue the practical completion certificate for the project. During the Defect Liability Period which commences on completion of the work, the Engineering In charge shall inform or the contractor is expected to be informed of any defective works by the Employer’s representative of the defects and make good at contractor’s cost with an intention of giving opportunity to the contractor of making good the defects appeared during that period. It is the contractor’s obligation under the contract to rectify the defects that appear during Defect Liability Period and the contractor shall within a reasonable time after receipt of such instructions comply with the same at his own cost. The Engineering In charge/Project Officer shall issue a certificate to that effect and completion of making good defects shall be deemed for all the purpose of this contract to have taken place on the day named in such defect liability certificate.
- If defective work or workmanship or design have been knowingly covered-up or concealed so as to constitute fraud, commencement of the Defect Liability Period may be delayed. The decided period may be delayed until discover actually occurs on at least the defect could have been discovered with reasonable diligence, whichever is earlier.
- New DLP shall be as below:

Department	Type of Works	DLP
S.W.D.	SWD pipe drain/ Box drain/Culvert /Nalla Construction	5 years
	SWD Collapse walls	3 years
	SWD Civil Repairs in desilting works	1 year
	SWD Pumping Station, holding pond	10 years
Road	C.C.Road.	10 years
	Asphalt Road	3 years

- Also, in case of defect, the Engineer shall give notice to the Contractor of any Defects before the end of the Defects Liability Period, which begins at. The Defects Liability Period shall be extended for as long as Defects remain to be corrected. Every time notice of Defect/Defects is given, the Contractor shall correct the notified Defect/Defects within the duration of time specified by the Engineer’s notice. The Engineer may issue notice to the Contractor to carry out removal of defects or deficiencies, if any, noticed in his inspection, or brought to his notice. The Contractor shall remove the defects and deficiencies within the period specified in the notice and submit to the Engineer a compliance report.
- It is the Completion Stage when the contractor has completed all of the works and fixed all of the defects that were on the list of issue by Engineer-in-charge. When this happens, the engineer must issue a ‘Certificate of Completion’. On the issue of ‘Certificate of Completion’, the ‘Defect Liability Period ‘starts. The contractor also must issue a ‘Certificate statement’ as an

acknowledgment to the engineer not later than 14 days after the 'Certificate of Completion' has been issued. During the 'Defect Liability Period', the contractor has to obey all written instructions from the engineer to carryout repairs and fix any defects which appear in the Permanent Works. If the contractor does not ,due to his own faults finish the repair works or fix the defects by the end of 'Defect Liability Period', the 'Defect Liability Period' will continue until all works instructed by engineer is done.

SECURITY DEPOSIT AND PERFORMANCE GUARANTEE

A. Security Deposit

The security deposit shall mean and comprise of

- I. Contract Deposit and
- II. Retention Money.

I. Contract Deposit – The successful tender, here after referred to as the contractor shall pay an amount equal to **two (2) percent** of the contract sum shall be paid within thirty days from the date of issue of letter of acceptance.

II. Retention Money – The contractor shall pay the retention money an amount equal to **five (5) percent** of the Contract Sum which will be recovered from the contractors every bill i.e. interim / running / final bill and same shall be refunded after completion of DLP period or finalization of Final bill **whichever is later.**

B. Additional Security Deposit

The additional security deposit will be applicable when a rebate of more than of 12 % at the rate of with no maximum limit. The ASD is calculated as follows: -

The ASD shall be paid offline and shall be applicable as under :-

Sr. No.	Rebate quoted by bidder	ASD applicable
1	Up to 12% rebate	No ASD
2	12.01% to 20% rebate	1% of Estimated Cost for each percentage & part thereof above 12% of rebate quoted.
3	20.01% rebate and above	8% + 2% extra for each percentage and part thereof over and above 20% of rebate quoted.

It is proposed to accept the A.S.D as applicable from respective bidders in the form of Demand Draft, which is to be submitted one day before opening of Packet 'C' before 5.00pm to the respective Head Clerk (Expenditure) of S.W.D Division in sealed envelope. If the bidders fails to submit the A.S.D applicable or submit inadequate A.S.D, in the form of D.D at least one day before opening of Packet C before 5.00pm then the E.M.D of the respective bidder will be forfeited.”

Further if A.S.D is not applicable to the bidder, then the bidder has to submit a “NIL” report in seal Envelope to the respective Head Clerk (Expenditure) of S.W.D Division, one day before opening of Packet 'C' before 5.00pm .

C. Performance Guarantee:

The successful tender, here after referred to as the contractor shall pay in the form of “Performance Guarantee” at different rates for different slabs as stated below:

Offer	PG applicable %
For premium, at par and rebate 0 to 12%	PG= 0.92 % x Contract sum Applicable for rebate of 12%
For rebate of 12.01 % and above	PG= (0.92% x Contract Sum applicable for rebate of 12%) +(X) x Contract Sum where X= percentage rebate quoted more than 12%.

Note: Contract sum shall mean amount after application of rebate/premium as quoted by the contractor with contingencies only and excluding price variation.

The PG shall be paid in one the following forms.

1. Cash (In case guarantee amount is less than Rs.10,000/-
2. Demand Draft (In case guarantee amount is less than Rs.1,00,000/-)
3. Government securities
4. Fixed Deposit Receipts (FDR) of a Schedule Bank.
5. An electronically issued irrevocable bank guarantee bond of any Schedule bank or if in the prescribed form given in Annexure.

Performance Guarantee is applicable over and above the clause of Security Deposit. Performance Guarantee will have to be paid & shall be valid till the defect liability period or finalization of final bill whichever is later.

This deposit will be allowed in the form of I to V as mentioned above and shall be paid within 15 days after receipt of Letter of Acceptance.

D. Refund of Security Deposit

i. Refund of Contract Deposit

The Contract Deposit shall be released within 30 days after completion of DLP (in case of 1 or 3 or 5 years DLP) and after issue of 'Defect Liability Certificate' subject to no recoveries are pending against the said work, provided that the Engineer is satisfied that there is no demand outstanding against the Contractor. No claim shall be made against the Balance Contract Deposit after the issue of Defects Liability Certificate.

The Contract Deposit shall be released within 30 days after completion of 5 year of DLP (in case of 10 years DLP) and after issue of 'Defect Liability Certificate' subject to no recoveries are pending against the said work, provided that the Engineer is satisfied that there is no demand outstanding against the Contractor. No claim shall be made against the Balance Contract Deposit after the issue of Defects Liability Certificate

ii. Refund of Retention Money

Retention Money shall be released within 30 days after completion of Defect Liability Period.

iii. Refund of Additional Security Deposit-

The additional security deposit shall be released within 30 days of issue of 'Certificate of Completion' with respect to the whole of the Works. In the event the Engineer issues a Taking-over Certificate for a section or part of the Permanent Works, only such proposition thereof as the Engineer determines (having regard to the relative value of such section or part of the Works) shall be considered by the Engineer for payment to the Contractor.

iv. Refund of Performance Guarantee –

❖ Summary of time of Refund of deposit is tabulated as follows:

A) Time of Refund for works having 10 years DLP

Deposits refunded after completion	After 5 years of DLP	After Completion of DLP
ASD	CD	PG+100% of RM

B) Time of Refund for works having 1 or 3 or 5 years DLP

Deposits refunded after completion	After Completion of DLP
ASD	CD + 100% of RM + PG

Note: Please refer Circular No.CA/F/Projects/ 36 dtd 07.12.2020.

- It shall be clearly mentioned that the BG shall be applicable for individual work/contract and clubbing of various contracts of the said contractor will not be allowed. In case of obtaining Bank Guarantee, it is necessary to mention that the same shall be valid further 6 months from the completion of defect liability period/ warranty period.
- It shall be the responsibility of the bidder to keep the submitted B.G. "VALID" for the stipulated time period in the tender & in case of its expiry it will attract penalization.
- Bank Guarantee should be issued by way of General Undertaking and Guarantee issued on behalf of the Contractor by any of the Nationalized or Scheduled banks or branches of foreign banks operating under Reserve Bank of India regulations located in Mumbai upto Virar & Kalyan. List of approved Banks is appended at the end of Instructions to Bidders (ITB). The Bank Guarantee issued by branches of approved Banks beyond Kalyan and Virar can be accepted only if the said Bank Guarantee is countersigned by the Manager of a Regional Branch of the same bank within the Mumbai City Limit categorically endorsing thereon that the said Bank Guarantee is binding on the endorsing Branch of the Bank or the Bank itself within Mumbai Limits and is liable to be enforced against the said Branch of the Bank or the bank itself in case of default by the Contractors furnishing the Bank Guarantee. The Bank Guarantee shall be renewed as and when required and/or directed from time to time until the Contractor has executed and completed the works and remedied any defects therein.

E. Legal + Stationary Charges: (As per applicable circular)

Successful tenderer shall pay the Legal Charges +Stationary charges as per Circular no **legal Dept. /03 dtd 22.06.2021.**

Contract Value		Legal+ Stationery Charges
From Rs. 10,001/-	To Rs. 50,000/-	Nil
From Rs. 50,001/-	To Rs. 1,00,000/-	Rs. 5,710/-
From Rs. 1,00,001/-	To Rs. 3,00,000/-	Rs. 9,430/-
From Rs. 3,00,001/-	To Rs. 5,00,000/-	Rs. 11,330/-
From Rs. 5,00,001/-	To Rs. 10,00,000/-	Rs. 13,190/-
From Rs. 10,00,001/-	To Rs. 20,00,000/-	Rs. 15,060/-
From Rs. 20,00,001/-	To Rs. 40,00,000/-	Rs. 16,960/-
From Rs. 40,00,001/-	To Rs. 1,00,00,000/-	Rs. 18,830/-

From Rs. 1,00,00,001/-	To Rs. 10,00,00,000/-	Rs. 22,220/-
From Rs. 10,00,00,001/-	To Rs. 20,00,00,000/-	Rs. 25,650/-
From Rs. 20,00,00,001/-	To Rs. 30,00,00,000/-	Rs. 29,070/-
From Rs. 30,00,00,001/-	To Rs. 40,00,00,000/-	Rs. 32,490/-
From Rs. 40,00,00,001/-	To Rs. 50,00,00,000/-	Rs. 35,880/-
From Rs. 50,00,00,001/-	To Rs. 100,00,00,000/-	Rs. 42,720/-
From Rs. 100,00,00,001/-	To Rs. 2,00,00,00,000/-	Rs. 52,970/-
From Rs. 200,00,00,001/-	To Rs. 3,00,00,00,000/-	Rs. 59,790/-
From Rs. 300,00,00,001/-	To Rs. 4,00,00,00,000/-	Rs. 68,290/-
From Rs. 400,00,00,001/-	To Rs. 5,00,00,00,000/-	Rs. 76,820/-
From Rs. 500,00,00,001/-	Up to any limit	Rs. 85,380/-

The tenderers are requested to note that stationary charges as given in the table above will be recovered from the successful tenderer for supply of requisite prescribed forms for preparing certificate bills in respect of the work.

E. Stamp Duty: (As per applicable circular)

It shall be incumbent on the successful tenderer to pay stamp duty on the contract as per circular u/no. O.No./ Imp-1/Work Contract/ 396/2016 dated 23.02.2016.

- I.** As per the provision made in Article 63, Schedule I of Bombay Stamp Act 1958, stamp duty is payable for “works contract” that is to say, a contract for works and labour or services involving transfer of property in goods (whether as goods or in some other form) in its execution and includes a sub-contract, as under :

(i)	Where the amount or value set forth in such contract does not exceed rupees Ten lakhs	Five Hundred rupees stamp Duty
(ii)	Where it exceeds rupees Ten lakhs	Five hundred rupees plus 0.1% of amount above rupees subject to the maximum of rupees twenty five lakhs stamp duty.

- II.** The successful bidder shall enter into a contract agreement with M.C.G.M. within 30 days from the date of issue of Work Order and the same should be adjudicated for payment of Stamp Duty by the successful bidder.
- III.** Further shortfall if any, in amount of stamp duty paid as against prescribed amount for the documents executed in Mumbai City & Mumbai Suburban District be recovered from the concerned work contractors and to deposit the deficit or unpaid Stamp Duty and penalty by two separate Demand Draft or Pay Order in favor of “Superintendent of Stamp, Mumbai” within 15 days from intimation thereof.
- IV.** All legal charges and incidental expenses in this respect shall be borne and paid by the successful tenderer.
- V.** As per para 54 read with 40(b) of Maharashtra Stamp duty Act, Stamp duty at the rate of 0.5 % is payable on total amount of Bank Guarantee submitted by Tenderer. If the time period of the Bank required to extend then the same shall be considered as new Bank Guarantee and again 0.5% stamp duty shall be applicable.

IMPORTANT DIRECTIONS

1. All the information uploaded shall be supported by the corroborative documents in absence of which the information uploaded will be considered as baseless and not accepted for qualification criteria. All the documents shall be uploaded with proper pagination. The page No. shall be properly mentioned in the relevant places.
2. The information shall be uploaded in the sequence as asked for with proper indexing etc. The Bidder shall be fully responsible for the correctness of the information uploaded by him.
3. Applicants/Bidders shall refer portal.mcgm.gov.in\tenders for “The Manual of Bid-Submission for Percentage Rate/Item Rate Tender Document.” The detail guidelines for creation and submission of bid are available in the referred document. Any queries or request for additional information concerning this TENDER shall be submitted by e-mail to **se01city.swd@mcgm.gov.in** The subject shall clearly bear the following identification/ title: **CT-60** work of construction of RCC box drain of size 4m x 2m along Sion-Mahim link road from piwala Bunglow up to T-Junction in G/N ward..” Any changes in Email ID shall be intimated on the portal.
4. In case of **Equal Percentage** of lowest bidders (L1), the allotment of work shall be done by giving 48 hrs (**2 working days**) from the day of opening of packet C on same BID-Document number for re-quoting and such development needs to done by IT department in MCGM’s SRM system. **Till such development is made; ‘Sealed Bids’ shall be called from the bidders quoting the same rates i.e.L1.**

In case of equal percentage of lowest bidders is obtained even after re-quoting, then the successful bidder will be decided by lottery system by concerned Ch.Eng.The bidder shall need to submit the additional ASD if applicable within 7 days after receipt of notification issued by concerned **Dy. Chief Engineer (SWD) City**. Also, the Performance Guarantee shall be paid in 15 days after receipt of Letter of Acceptance.
5. As per circular CA/F/Project/17 of 06.09.19“Chapter XXI-Miscellaneous, Section 171(1) of GST Act, 2017 governs the “Anti Profiteering Measures” (AFM). As per the provision of this section. Any reduction in Page 48 rate of tax on any supply of goods or services or the benefit of input tax credit shall be passed on to the recipient by way of commensurate reduction in prices. Accordingly, the contractor should pass on the complete benefit accruing to him on account of reduced tax rate or additional Input tax credit, to MCGM. Further, all the provision of GST Act will be applicable to the tender.”
 - As per MGC/F/7867 dt 12/10/15 All excavated & surplus material on site will be disposed by next of transportation or as directed by Site in charge on the cost of contractor. No additional / separate payment will be done to contractor.
 - As per circular MGC/F/7076 dt 30/08/18 It is directed to dispose of construction and demolition waste material by following due procedure in accordance with the provision of the Construction and Demolition Waste Management Rules-2016.

- As per circular U/No. MGC/F/6342 dated 5.5.2018, Barricading shall be provided free of cost as per Circular vide u/no. MGC/F/6342 dated 5.5.2018 and as per Annexure I, II and III of Standard drawings and specifications with slogans and department wise color codes.” The copy of circular is attached to this tender as a part of tender document.
- As per circular no. CA/FRT/623 dt 8/10/12 The party of second part shall duly observe & comply with all the provisions of law, rules & regulations referred by government / Municipal Corporation or any other competent authority applicable to the said tender work & the activity being conducted therein. Also, as per the circular CA/FRI/12 dtd. 21/06/12, 1% amount of labour cess will be recovered.
- As per circular MGC/F/6565 dated 25.09.2018 The bidder shall disclose the Litigation History in Packet ‘B’ under the heads “Details of Litigation History”. If there is no Litigation History, the bidder shall specifically mention that there is no Litigation History against him as per the clause of Litigation History.

Municipal Corporation of Greater Mumbai

No. Dy.Ch.Eng./SWM/3957/Op. dt. 10/9/2018

CIRCULAR

28-9-2018

Subject: Implementation of the Construction and Demolition Waste Management Rules, 2016

Reference: i) Hon'ble Supreme Court's order in the Special Leave Petition (civil) No: D 23708/2017, dated 15/03/2018
ii) Hon'ble M.C. Sir's Approval u/no. MGC/F/7076 dtd. 30.08.2018

The Construction and Demolition Waste Management Rules, 2016 is applicable to 'every waste resulting from construction, re-modeling, repair and demolition of any civil structure of individual or organisation or authority who generates construction and demolition waste such as building materials, debris, rubble'.

Hon'ble Supreme Court vide order dated 15/03/2018, has directed to dispose of construction and demolition waste material by following due procedure in accordance with the provisions of the Construction and Demolition Waste Management Rules, 2016".

In order to put curb on the un-authorisedly dumped waste, it is essential to control it by asking ward Maintenance department or any MCGM department to issue work-permission only after assessing the total estimated quantity of C&D waste likely to be generated out of the repairs / construction / trenching work or any such civil works, and asking them to make payment in advance or in stages of waste generation for the 'Debris on Call' system or transport C&D waste to designated unloading site.

Following standard operating procedure is proposed to be adopted:

- 1) MCGM department like A. E. (Maintenance), A. E. (B&F), H.E., S.O., S.P., M.S.D.P., W.S.P., S.W.D., S.W.M., C.E., B.C., B.M., Roads, Bridges, etc. carrying out civil work / repairs works etc. shall put condition in the tender / quotation / work order to dispose of C&D waste generated either by (i) 'Debris on Call' scheme if generation of C&D waste is less than 300MT for entire project or (ii) contractor shall transport to designated unloading site approved by MCGM S.W.M. department by following due procedure if C&D waste is more than 300MT for entire project.
- 2) The estimated quantity of the C&D waste generated shall be certified by A.E. (Maintenance) Ward or the concerned department.
- 3) If quantity of C&D waste is less than 300MT, A. E. (S.W.M.) Ward will issue Challan for making payment as per 'Debris on call' scheme on approval from Zonal Ex. Eng. (S.W.M.).
- 4) If quantity of C&D waste is more than 300MT, the contractor / agency will submit C&D waste management plan complete with requisite documents to Zonal Ex. Eng. (S.W.M.). On approval, the contractor / citizen / agency carrying out the civil works will be allowed to transport the C&D waste material to the designated unloading site.
- 5) The contractor / citizen / agency carrying out the civil works shall maintain & submit the appropriate record like date, quantity of C&D waste transported, vehicle No., Challan of Receipt of C&D waste from unloading site etc.
- 6) The whole system of issuing NOC for C&D waste transportation and payment will be made ONLINE and for this M/S. Softtech will be asked to develop appropriate software on the basis of existing norms being done for auto-DCR portal.
- 7) The proposals will be processed manually till the complete system fully operational online.
- 8) All the contractors / agencies using designated unloading site must maintain proper record of the C&D waste generated and transported along with date and vehicles through which C&D is transported & the copies of Challans from unloading site for having unloaded the C&D waste and submit the same to A.E. (S.W.M.) ward through concerned department.

Sd/-07/08/2018
Ch. Eng. (S.W.M.)

Sd/-07/08/2018
D.M.C. (S.W.M.)

Sd/-10/08/2018
A.M.C.(E.S.)

Sd/-29/08/2018
Municipal Commissioner

Ch Eng (SP)

Submitted, please.

Dy. Ch. Eng. (S.W.M.)

50

MUNICIPAL CORPORATION OF GREATER MUMBAI

No. : MGC/F/6565 dtd. 25-9-2018

CIRCULAR

Sub : Setting up the parameters of litigation history of the bidders

As approved by Hon'ble M.C., the clause of litigation history be included as part of SBD as below :-

- 1) The bidder shall disclose the litigation history in Packet 'B' under the head "Details of Litigation History".

If there is no Litigation History, the bidder shall specifically mention that there is no Litigation History against him as per the clause of Litigation History. In case there is Litigation History -

Litigation History must cover - Any action of blacklisting, debarring, banning, suspension, deregistration and cheating with MCGM, State Govt., Central Govt. or any authority under State or Central Govt./Govt. organisation initiated against the company, firm, directors, partners or authorized signatory shall be disclosed for last 5 years from the date of submission of bid. Also, bidder must disclose the litigation history for last 5 years from the date of submission of bid about any action like show cause issued, blacklisting, debarring, banning, suspension, deregistration and cheating with MCGM and MCGM is party in the litigation against the company, firm, directors, partners or authorized signatory for carrying out any work for MCGM by any authority of MCGM and the orders passed by the competent authority or by any Court where MCGM is a party. While taking decision on litigation history, the concerned Chief Engineer or D.M.C. or Director, as may be the case, should consider the details submitted by bidder and take decision based on the gravity of the litigation and the adverse effect of the act of company, firm, directors, partners or authorized signatory on the MCGM works which can spoil the quality, output, delivery of any goods or any work execution and within the timeframe.

- 2) The litigation history shall be treated as curable defect and hence, the portion/clause of SBD, (C) Bid Capacity at Pg. 15 & in the chapter of 'Instructions to Applicants' at Pg. 31 of the SBD will be now corrected by deleting the word litigation history and shall be read as below.

C) Bid Capacity :

The bid capacity of the prospective bidders will be calculated as under: Assessed Available Bid Capacity = $(A * N * 2 - B)$

Where,

- A = Maximum value of Civil Engineering works executed in any one year (year means Financial year) during the last five years (updated to the price level of the Financial year in which bids are received at a rate of 10% per year) taking into account the completed as well as works in progress.
- N = Number of years prescribed for completion of the Project/Works, excluding monsoon period, for which these bids are being invited. (E.g. 7 months = 7/12 year). For every intervening monsoon, 0.33 shall be added to N.
- B = Value of existing commitments (only allotted works) on the last date of submission of bids as per bidding document and on-going works to be completed during the period of completion of the Project/Works for which these bids are being invited.

Note: The statement showing the value of existing commitments and on-going works as well as the stipulated period of completion remaining for each of the works listed should be attached along with certificates duly signed by the Engineer-in Charge, not below the rank of an Executive Engineer or equivalent.

Even though the bidders meet the above qualifying criteria, they are subject to be disqualified if they have:

- made misleading or false representation in the forms, statements and attachments submitted in proof of the qualification requirements; and/or
- Record for poor performance such as abandoning the works, not properly completing the contract, inordinate delays in completion, litigation-history, or financial failures etc."

All the concerned are directed to implement the above directions with immediate effect.

No. Dir./L&T/P/915/MC
27.9.18

Back 27/09/18
Director (E. S. & P.)

City Engineer/Ch.Eng.(Roads & Traffic) / Ch.Eng. (Bridges) / H. E. / Ch.Eng. (WSP) /Ch.Eng.(S.P.) /Ch.Eng(S.O.)/ Ch.Eng.(MSDP) / Ch.Eng. (BM) / Ch.Eng.(Vig) / Ch.Eng. (M&E) / Ch.Eng.(D.P.)/Ch.Eng.(SWD) / Ch.Eng. (Coastal Road) / Ch.Eng.(SWM) / Ch.Eng.(CTIRC)/Dv. Ch.Eng.(HIC) / Dv.Ch.Eng.(SIC), Supt. of Gardet ✓

Asstt. Comm. Ward / Asstt. Comm.(Markets) / Asstt. Comm. (Estate) / Asstt. Comm.(Planning) / Asstt. Comm.(R.E.) City/W.S./E.S.

(S)
पुणेमध्ये महानगरपालिका प्रमुख अथवा
भलनिवारण प्रकल्प यांचे कार्यालय
वरवी. 5164/P.
29 SEP 2018
सा. प्र. अ. (ग. प्र.)
उप. प्र. अ. (ग. प्र.) निवारण, वी. प्र. व. प्र.
प्र. अ. (ग. प्र.) आर. प्र.
कार्य. अ. (ग. प्र.) महापालिका

DY. Ch. E. (S.P.) Const/P&D
A.O.(S.P.(G)/Const/P&D
*do justice
needful
file 29/9*
Chief Engineer
(Swe. Project)

- EE (SP)P&D - City/ES/W/S/Micro
- A.O. (SP) - Generat/Estt/Const/P&D
- 1. Put Compliance
- 2. P
- 3. For Nim
- 4. Please Circulate

All to note & instant
concerned staff accordingly
file
Dy. Ch.E(S)P&D

Sodaye
This is the part
of tender document
[Signature]
3/10/18

SECTION 7
SCOPE OF WORK

SCOPE OF WORK

Name of the Work: CT-60 work of construction of RCC box drain of size 4m x 2m along Sion- Mahim link road from piwala Bunglow up to T-Junction in G/N ward.

Scope of Work:-

Major works.

1. Construction of RCC Box drain of size 4m x 2m (For box drain construction, 50% work of slab by cast-in-situ methodology and 50% work of slab by precast methodology)
2. Reinstatement of road in C.C.

Estimated cost of the work: - Rs 33,99,12,418/-

Note:

- All the works contained in the scope of work shall be carried out strictly as per relevant specifications applicable as attached or referred to, in this tender document.
- The above is general description of the scope of work and actual work mentioned above shall be governed by B.O.Q. and as directed by the Engineer-in-Charge.
- Applicable schedules.- Unified schedule of rates with cognizance of GST for S.W.D., Building construction, Road works, Bridge works, Hydraulic Engineering, Sewerage Projects etc. **effective from 01.06. 2018**

SECTION 8
BILL OF QUANTITIES

Estimated cost- 33,99,12,418/-

Name of Work: CT - 60:- Work of construction of RCC box drain of size 4 m x 2m along Sion Mahim- link road from Piwala Bunglow up to T-junction in G/N ward.

ABSTRACT SHEET

Sr.No.	Item No.	Description of Item	Unit	Total Qty	Rate	Amount
1	R2-SWD-74	Providing and laying 300mm dia NP2 Class R.C.C. hume pipes with Collar joints conforming to IS 458:2003 and laid on approved bedding as per IS 783:1985 (reaff. 2010) including jointing the pipes and filleting with hemp and stiff mix of cement mortar 1:2, including testing of pipes at contractors costs (in presence of municipal staff) as per IS 3597 etc. complete as specified & as directed by Engineer in Charge. (excluding necessary earthwork & bedding).	Rmt	300.00	1180	3,54,000.00
2	R2-SWD-82-A	Providing and laying 1000mm dia NP3 class RCC hume (spigot & socket ended) pipes with rubber ring roll on joints confirming to IS 458:2003 and laid on approved bedding as per IS 783:1985 (reaff.2010) including jointing the pipes and filleting with stiff mix of cement mortar 1:2 , including testing of pipes (in	Rmt	25.00	8974	2,24,350.00
3	R2-CS-DD-59	Removing and refixing G.I. pipes of any size with all new fittings if necessary complete including cleaning and painting.	Rmt	200.00	192	38,400.00
4	R2-CS-EW-1	Excavation for foundation,	Cum	15780.00	307.00	48,44,460.00

		substructures, basemen				
5	R2-CS-EW-2-a	Extra over above item CS-EW-1 for lift from 1.5m to 3.0m.	CUM	3950.00	71	2,80,450.00
6	R2-CS-EW-2-b	Extra over above item CS-EW-1 for lift from 3.0m to 4.5m	CUM	3700.00	106	3,92,200.00
7	R2-CS-EW-2-c	Extra over above item CS-EW-1 for lift from 4.5m to 6.0m	CUM	3600.00	171	6,15,600.00
8	R2-CS-EW-5	Excavation by using splitters for foundations, substructures, basements, tanks, sumps, walls, chambers, manholes, trenches, poles, pits & general building works in hard rock, reinforced concrete, for depths/lifts up to 1.5M, including drilling, breaking in small pieces, mucking, dressing/trimming the sides, leveling of bottoms, manual de-watering, removing rank vegetation, backfilling in layers not more than 200mm thickness, watering, consolidating, compacting to achieve not less than 97%	Cum	3600.00	3,104.00	1,11,74,400.00
9	R2-RW-10-55	Excavation in Reinforced OR pavement grade concrete M-20 & above by using modern machinery (poclain with rock breaker, etc.) including with stacking of excavated material within 150 m radius etc complete upto any depth as specified & as directed, by the Engineer.	CUM	960.00	1525	14,64,000.00
10	R2-RW-7-01	Removing & refixing traffic regulatory boards/bus stop boards/street name boards etc. in M-10 cement concrete, complete as directed.	Each	2.00	881	1,762.00
11	R2-RW-7-05	Cutting down existing stone/brick masonry compound walls, abutments, piers, wing-walls etc. including stacking the rubble, khandkies etc. in stack, as directed (Actual	Cum	18.00	211	3,798.00

		volume of structure will be paid.)				
12	R2-CS-EW-13	Providing and removing open or closed shoring and strutting in the trenches/ pits for all depths as per specifications/ drawings and or as directed by Engineer-in-charge by including walling, struts,.	Sqm	180.00	715	1,28,700.00
13	R2-CS-EW-14	Providing and leaving permanently in position the open or closed shoring and strutting in the trenches/ pits for all depths as per specifications/ drawings and or as directed by Engineer-in-charge including walling, struts, open poling boards, horizontal sheeting, runners, dog spikes by using	Sqm	36.00	1372	49,392.00
14	R2-CS-CW-2-a-1	Providing and laying in position ready mixed plain cement concrete,using fly ash and cement content as per approved design mix from Engineer-in-charge and fly ash conforming to grade I of IS 3812 (Part-1) only be used as part replacement of OPC as per IS 456 and uniform blending with	Cum	360.00	6963	25,06,680.00
15	R2-SWD-178	Providing & placing in position controlled Ready Mix Concrete of grade M-40 in raft slab by using Ordinary Portland Cement including transportation to site anywhere in Mumbai including curing by any means etc. complete as directed by Engineer-in-Charge. (Reinforcement & Formwork shall be paid		1200.00	7777	93,32,400.00

		separately).				
16	R2-SWD-179	Providing & placing in position controlled Ready Mix Concrete of grade M-40 in walls and deck slab above or below ground level at any height / depth by		1540.00	9569	1,47,36,260.00
17	SD -08-012-FA2	Providing 300 MM dia touch pile	Rmt	21333.33	4214.00	8,98,98,666.67
18	R2-SWD-25	Providing and placing in position controlled cement Ready Mix Concrete of M-25 grade in raft slab by using ordinary portland cement including curing by any means, as specified & as directed by Engineer-in-Charge. (Reinforcement and form work will be paid separately).	Cum	1507.20	6979.00	1,05,18,748.80
19	R2-CS-CW-30-b	Centering and shuttering of steel plates with M.S. Angles including strutting, propping etc. and removal of form for : Walls (any thickness) including attached buttresses, retaining wall, shear wall, diaphragm wall etc	Sqm	1600.00	558	8,92,800.00
20	R2-CS-CW-35-e	Corrosion Resistant Steel (500 CRS D)	MT	860.00	82356	7,08,26,160.00
21	R2-SWD-154	Providing & Fixing 100 mm. dia PVC. Pipes of approved quality as weep holes in nalla/retaining walls etc complete as directed by Engineer-in-Charge.	Rmt	100.00	355	35,500.00
22	R2-SWD-144	Supplying and fixing C.I. steps weighing 5.44 kg. each conforming to IS 5455-1969 (reaffirmed 2003) etc., complete as specified and as directed by Engineer-in-Charge..	Each	150.00	716	1,07,400.00
23	R2-SWD-	Supplying and fixing 0.90m x 0.60m internal size of	Each	28.00	31371	8,78,388.00

	148	rectangular C.I. air-tight cover and frame weighing minimum 270 of material grade of min. FG 150 conforming to IS 210:2009 and specification no SP-SWD- 3 with the grade designation of HD 20 conforming to IS 1726:1991including testing as per CL 10 and inspection as per CL.11 of IS 1726:1991, as per specification as per Standard Specification no SP-SWD-3, etc. complete, as specified and as directed by Engineer in Charge.				
24	R2-RW-7-08	Breaking & removing existing cement concrete slab over culvert copping etc., by any means etc. complete as directed	Cum	3.00	1315	3,945.00
25	R2-RW-8-03	P/L 300mm dia. R.C.C. hume pipes, NP2 class, jointing, filletting in 1:1 C.M., including plugging of both the	Rmt	796.00	946.00	7,53,016.00
26	R2-SWD-38	Providing Brick masonry in cement mortar 1:5 as specified & as directed by Engineer-in-Charge.	Cum	30.00	11670	3,50,100.00
27	R2-SWD-47	Constructing uncoursed rubble masonry in cement mortar 1:4 of first sort (with contractor's rubble), as specified & as directed by Engineer- in-Charge.	Cum	25.00	6,695.00	1,67,375.00
28	R2-SWD-60	Providing 25 mm thick cement plaster in cement mortar 1:2 including neat cement rendering (without water proofing compound) as specified & as directed by Engineer-in-	Sqm	200.00	504	1,00,800.00
29	R2-CS-EW-26	Providing & Laying dry stone Rubble Soling with average 230 mm size hard stone set in regular	Cum	150.00	2231	3,34,650.00

		lines, handpacked and interstices thoroughly filled with small chips including filling in with good quality murum brought from outside, compacting with iron rammers, watering, sand spreading 12mm thk. layer of grit on top etc complete as directed by Engineer In Charge. (Note: The rate includes the royalty and other taxes if any)				
30	R2-FA2-SWD-PR-20	Providing and placing in position controlled cement concrete M-45 grade using minimum cement content as 400Kg/cum and max water cement ratio of 0.40 for MATCH CASTING OF SEGMENTS IN CASTING YARD drawings and designs including projections, moulding, chamfers etc. of required shape and size including levelling, compacting by vibrators, curing, finishing the exposed surfaces including formwork, shuttering and centering as necessary and required etc. complete as specified and directed, staging properly, loading at yard and unloading at site, placing etc complete. (excluding reinforcement) (U SHAPED)	Cum	600.00	41,473.00	2,48,83,800.00
31	R2-BW-5-3-f	Providing and applying protective paint consisting of two coats of coat TAR epoxy paint over one coat of primer of approved quality and make to the external surfaces of concrete structures to be buried under the soil etc. complete as specified and directed		3200.00	281	8,99,200.00
32	R2-BW-	Providing and applying	Sqm	1600.00	412	6,59,200.00

	5-3-c	epoxy base paint to RCC piers, columns, beams,girders, diaphragms, slabs, parapets etc. including cleaning the surfaces thoroughly so as to remove deposited salts, oil, grease, tar, moisture etc.from the surface, preparing the surface, applying putty consisting of epoxy base paint and steolite powder, to render the concrete surfaces smooth by covering small irregularities and applying one coat of epoxy paint including scaffolding etc. complete as specified and directed.(2 coats epoxy + primer)				
33	R2-RW-2-21	Providing & laying, spreading & compacting specified crushed stone in granular sub base course including premixing the material in mechanical mixer (pug mill or approved type), spreading of mixed material in uniform layer of 100 mm to 75 mm (compacted thickness each) with motor grader or paver on prepared murum surface & compacting with 10 all	Cum	5200.00	2547	1,32,44,400.00
34	R2-CS-CW-7-d	Providing and laying in position ready mixed design mix M - 20 grade cement concrete for reinforced cement concrete work, using cement content as per approved design mix, including pumping of concrete to site of laying and the cost of centering, shuttering, finishing and excluding reinforcement, including admixtures in recommended proportions as per IS: 9103 to	Cum	216.00	9556	20,64,096.00

		accelerate, retard setting of concrete, improve workability without impairing strength and durability as per direction of Engineer-in-charge. The Mix design as per particular specifications shall be got approved by Engineer-in-Charge before execution of the item. The rate shall include cost of all specified materials and operations at all levels and heights, including the cost of centering, shuttering and excluding reinforcement which shall be paid under relevant item. (Note :- Cement content considered in this item is @ 300 kg/cum as per IS 456 table showing				
35	R2-CS-CW-7-a	Foundations, footings, bases of columns, rafts, pilecap	Cum	10.00	7515	75,150.00
36	R2-CS-CW-7-b	Walls (any thickness) including attached buttresses, retaining wall, shear wall, diaphragm wall, trench, pit walls, etc	Cum	10.00	10518	1,05,180.00
37	R2-CS-CW-7-c	Slabs, Suspended floors, roofs, landings, balconies, canopy and access platform	Cum	10.00	11790	1,17,900.00
38	R2-RW-1-09	P/L a top layer of earth of 15cm. Compacted thickness rolling with 10/12 tonne power roller, watering etc. complete in conformity with the lines, grades & cross sections & camber super elevation (Lab C.B.R. in soaked condition shall not be less than 10) including clearing & grubbing the ground etc. complete (including stabilisation if necessary.) as per New Road	Cum	10.00	1535	15,350.00

		Specifications clause no. 151.0				
39	R2-RW-2-20	Providing & laying, spreading & compacting graded crushed stone aggregate to wet mix macadam satisfaction	Cum	720.00	2937	21,14,640.00
40	R2-SWD-72	Providing and laying 150 mm dia NP2 class RCC hume pipes with collar joints conforming to IS 458:2003 & laid on approved bedding as per IS 783:1985 (reaff.2010) including jointing the pipes and filleting with hemp and stiff mix of cement mortar 1:2 including testing of pipes at contractor's cost (in presence of municipal staff as per IS 3597 etc. complete as specified & as directed by Engineer-in-charge. (excluding necessary earthwork & bedding)	Rmt	10.00	612	6,120.00
41	R2-RW-10-37	Providing and fixing of the precast TREE GUARD KERB of M-20 C.C. of height 230mm., width 100mm., Length 400mm., finished neatly, compacting, curing, formwork etc. including bedding of M-10 C.C. procured from M.C.G.M. approved R.M.C. plant, 10cm. thick, filling of jointing in C.M. 1:2 and painting the exposed surface with 3 coats of road marking paint, Grade I of approved colours and quality including single coat of.	Rmt	10.00	471.07	4,710.70
42	R2-RW-6-03	Raising or lowering circular manholes to the required level upto 20 cm. including all material, form work etc. with 16 cm. thick cement	Each	10.00	1151	11,510.00

		concrete M- 15 (1:2:4) c.c. coping under frame and cover of manhole, including curing etc. complete as specified and as directed				
43	R2-RW-6-05	Raising or lowering rectangular manholes to the required level upto 30 cm. including all materials, form work, brick work and with 16 cm. thick M-15 C.C. coping under frame & cover of manhole including curing etc. complete, as specified and as directed.	Each	10.00	2297	22,970.00
44	R2-SWD-141	Constructing double water entrance of internal size 0.60m x 1.20m with cast-in-situ coping in M-20 grade, fixing gratings in M -20 as per standard drawings (Dwg No. MCGM/SWD/2013-13), etc complete as specified and as directed by Engineer in Charge. (excluding excavation, providing and fixing of gratings and frame)	Each	28.00	17168	4,80,704.00
45	R2-SWD-176	Providing & Fixing 1.20m X 0.60m internal size of rectangular composite resin gully grating and frame (with minimum waterway areas 30% of internal size) of approved brand with grade designation C250 as per EN- 124 standard with bolt and lever type locking arrangement. gully gratings & frame shall have top abrasion resistant layer conforming to IS-15658:2006 and permissible permanent set value of 2 mm after the application of 2/3 test load in five continuous applications as per EN-124, the testing shall be performed in fully equipped and NABL	No	28.00	16755	4,69,140.00

		certified test lab with random batch test (2% of lot size) as per testing procedure stated in EN-124 standard, including testing ,inspection of material sample and finished product in presence of M.C.G.M. Engineers (3 nos.) at Manufacturers work, etc. complete as specified and as directed by Engineer in Charge. (Inspection shall be as per guidelines of IS and EN-124 standard specifications.				
46	R2-RW-7-04	Demolishing existing masonry, structures,(above & below G.L.) & carting away serviceable materials, to Ward Chowky & stacking the same, separately, as directed (Actual Volume of the masonry will be paid.)	Cum	10.00	708	7,080.00
47	R2-RW-1-05	Levelling, watering and rolling to 95% Standard Proctor Density with a power roller weighing not less than 10 tonnes and preparing the ground to the required grade and camber as specified as directed by the Engineer.	Sqm	4800.00	9.27	44,496.00
48	R2-CS-CW-58	Extra for spreading broken glass pieces under pavement 0.12 cu.m. of broken glass pieces per 10 sq.m. of area.	Sqm	600.00	45	27,000.00
49	R2-RW-10-32	Providing and laying Dry Lean Concrete base including providing coarse and fine aggregate to the specified gradation using minimum cement content 150 kg/cum of concrete with OPC 43 grade cement, mixing of oncrete as per approved design mix using mechanised batch	Cum	490.00	4481	21,95,690.00

		mix plant of appropriate				
50	R2-RW-10-16	Providing & fixing in position mild steel in tie bars of 12mm dia 55cm long & 45cm C/C whenever directed including handling , wrapping with paper for half length,fixing straightening, wastage etc. complete in all respect as directed.	Mt	1.17	63226	74,185.17
51	R2-RW-10-17	Providing & fixing in position M.S. dowel bars of 32mm dia 55cm long & 30cm C/C whenever directed including handling, fixing, etc. complete(no extra payment will be made for applying bitumen & grease to dowel bars)	MT	2.70	62904	1,69,840.80
52	R2-RW-10-33	Providing & laying M-40 C.C.avg. compressive strength 45 MPa and avg.flextural strength of 5.0 MPa (As per IRC 15-2002.N.1.6) procured from .C.G.M.approved R.M.C. plant including use of approved make plasticizer / retarder & Contractors water with ice flakes and sported by transit mixer and placing at work site. Compacting finishing, initial curing by approved curing compound & Contractors water and tarring the sides of slab with hot bitumen as s	Cum	900.00	7968	71,71,200.00
53	R2-RW-10-06	Providing & laying R.C.C. running beam in M-40 cement concrete including required formwork mixing, compacting & curing, etc. complete reinforced with 12mm dia.(Minimum 4 Nos.)M.S. main bars & 6mm Dia M.S. rings at 15cm/c/c to be anchored in slipper slab	Rmt	800.00	844	6,75,200.00

		properly with M.S. reinforcement as per drawing etc. complete as specified(Steel will not be paid separately).Contractor has to make his own arrangement for portable water for construction/curing with hessian cloth, etc. & will not be paid separately. Beam Size: b) 23cm. x 30cm.				
54	R2-RW-10-15	Providing & fixing high density polythene pipe of approved quality to fit around the dowel bars of 32mm dia at the end of expansion joints,fully greased inside, cotton waste the pipe around the dowel bars & the pipe duly capped at the end as directed.(H.D.P. pipe shall be 30cm in length) As shown in the drawing.	Each	756.00	31	23,436.00
55	R2-RW-10-18	Providing & laying waterproof paper of 40 GSM including overlap (to be not less than 10cm)etc. complete as specified as directed	Sqm	3200.00	11	35,200.00
56	R2-RW-10-19	Providing & constructing cement vatas in cm 1:10 at 0.6m * 0.6m c / c admeasuring 0.09m at bottom, 0.04m at top & 0.075m deep & maintaining the same throughout 14 days curing & removing the same thereafter as directed.	Sqm	3200.00	78	2,49,600.00
57	R2-RW-10-11	Cutting of construction & dummy/joints of M-35 C.C.& above slab by mechanical means within 10 to16 hrs.of casting of bay/slab as directed. A) transverse dummy joints 100mm deep/1/3 thickness of concrete pavement &6mm	Rmt	670.00	59	39,530.00

		wide.				
58	R2-RW-10-12	Cutting of construction & dummy/joints of M-35 C.C.& above slab by mechanical means within 10 to 16 hrs.of casting of bay/slab as directed. B) Longitudinal construction joints 100mm deep/ 1/3rd thickness of slab & 6mm wide	Rmt	1400.00	59	82,600.00
59	R2-RW-10-13	Providing & fixing in position premoulded asphalt filler 12mm thick conforming to I.S. 1838 of 1983 for placing of the expansion joint,around	Sqm	170.00	352	59,840.00
60	R2-RW-10-14	Providing & placing 5mm thick thermocole in dummy & construction joints immediately after cutting of joints & removing the same before dressing of dummy & construction joints etc. complete , as dirceted.	Sqm	210.00	76	15,960.00
61	R2-RW-10-46	Providing and fixing pre-cast Central Median divider Type- I of R.M.C.M-20 C.C. on Road as per drawing, finished neatly, compacting , curing, form work, etc, including beding R.M.C.M-10 C.C, 15 cm thick, filling of joints in C.M. 1:2 & painting the exposed surface with 3 coat of road marking paint, Grade-I of approved colour and quality including required excavation in C.C., asphalt etc. and removing the same any where in City & Sub limit, leveling the same as specified and as directed by the Engineer.(Note:- Every 10 dividers shall	Rmt	800.00	1685	13,48,000.00
62	R2 -RT -15 -04	Providing, casting and fixing (any where in city or suburban limit) precast reinforced	Rmt	100.00	6403	6,40,300.00

		<p>parabolic dividers in C.C.M 25, Type-5 as per drg. No. EET & C/Gen/013/03/Ty dt. 11.12.03 (Revised on 15/06/06) including providing, bending, fixing of reinforcement as per drawing, fixing the dividers on site in C.M. 1:2 for cushioning and jointing, filling the gap between dividers with C.C.M 15, curing, painting the exposed surface with road marking paint grade I (confirming to IS- 164) in two coats of approved colour including excavation in road portion and removing excavated material as per direction any where in city or suburban limit, cleaning the site etc. as directed by the engineer, The rate is inclusive of all lift and leads, transportation required for the work.</p>				
63	R2-RW-10-23	<p>Dressing of M-35 & above new C.C.pavement,dummy,transverse, longitudinal & expansion joints with hot rubberised sealing compoundconfirming to IS 1834-1984 after proper cleaning with compressedair,applying required primer & providing a layer of lime powder over hotsealing compound etc. complete as directed. A) Sealing 6mm wide dummy/transverse joints with a depth of 100mm/1/3rd thickness of concrete pavement.</p>	Rmt	670.00	92	61,640.00
64	R2-RW-10-24	<p>Dressing of M-35 & above new</p>	Rmt	1400.00	92	1,28,800.00

		C.C.pavement,dummy,transverse, longitudinal & expansion joints with hot rubberised sealing compound confirming to IS 1834-1984 after proper cleaning with compressed air,applying required primer & providing a layer of lime powder over hot sealing compound etc. complete as directed. B) Sealing of 6mm wide longitudinal joint with depth of 100mm./1/3rd thickness of concrete pavement.				
65	R2-RW-10-25	Dressing of M-35 & above new C.C.pavement,dummy,transverse, longitudinal & expansion joints with hot rubberised sealing compound confirming to IS 1834-1984 after proper cleaning with compressed air,applying	Rmt	230.00	60	13,800.00
66	R2-CS-PLG-5.1	Providing and installing in position permanent M.S. liners for piles of specified diameter and fabricated from 6.0mm to 8.0mm thick plates as per detailed drawings and designs including cutting, bending to required shape, welding, painting with Red Oxide paint etc. complete as specified and directed Use 6 mm MS liner.	Mt.	630.76	79777.00	5,03,19,785.96
67	R2 -RT -16 -32	Providing and applying hot applied thermoplastic road marking material with glass beads extremely high skid resistance 2.5mm thick without primer coat (tack coat) on asphalt road surface. All labour materials with special aggregates etc, as specified in B.S. part-I & II 1989 and	Sqm	64.00	727	46,528.00

		carrying out the marking on any road on center line and other lane marking continuous for intermittent 10cm or 15cm width and also pedestrian crossings stripes as well as spraying further quality of glass beads of type II uniformly into a mono layer on to the hot paint line in quick succession of the paint spraying operation @ 250gms per sq.mt. area as				
68	R2 -RT - 16 -33	Providing and applying hot applied thermoplastic road marking material with glass beads extremely high skid resistance 2.5mm thick with primer coat (tack coat) for binding on cement concrete road/paver blocks surface. All labour materials with special aggregates etc, as specified in B.S. part-I & II 1989 and carrying out the marking on any road on center line and other lane marking continuous for intermittent 10cm or 15cm width and also pedestrian crossings stripes as well as spraying further quality of glass beads of type II uniformly into a mono layer on to the hot paint line in quick succession of the paint spraying operation @ 250gms per sq.mt. area as directed and as per B.S./M.O.S.T. specification in white /yellow colour	sqm	240.00	662	1,58,880.00
69	R2 -RT - 16 -34	Supplying/ fixing of Two Way Raised Pavement Markers made of polycarbonate moulded body and reflective panels with micro prismatic lens capable of providing total internal reflection of the light	Each	400.00	427	1,70,800.00

		entering the lens face–				
70	R2 -RT - 16 -35	Supplying/ fixing of One Way Raised Pavement Markers made of polycarbonate moulded body and reflective panels with micro prismatic lens capable of providing total internal reflection of the light entering the lens face and shall support a load of 13635 kg tested in accordance to ASTM D 4280 Type H and complying to Specifications of Category A of MORTH Circular No RW/NH/33023/10 -97 – DO III Dt 11.06. 1997 . The minimum reflective area of 13 SqCm on NOS side and the slope to the base shall be 35 +/- 5 degree. Fixing will be without nails but by using epoxy resin based adhesive as per manufacturer's recommendation including site clearance etc and complete as directed by the engineer.	Each	50.00	420	21,000.00
71	R2-RW- 10-26	P/L ready mix cement concrete M-15cc having avg compressive strength 18.5 Mpa for foundation/encasement/ pavement/ cradle including form of mixing in batching plant, compacting by internal & surface vibrator, curing, finishing	Cum	360.00	6893	24,81,480.00
72	R2-CS- EW-3	Excavation for foundation, substructures, basements, tanks, sumps, walls, chambers, manholes, trenches, poles, pits & general building works in soft/ disintegrated rock, sandstone, stiff clay, gravel, cobblestone, hard laterite, water bound macadam, wet mix macadam, asphalt mix carpet of any type, pitc	cum	970.00	500	4,85,000.00

		<p>hing, soling, paths and hard core, lime concrete, plain cement concrete, stone masonry and all types of brick/block masonry below ground level, rock boulders, etc. for depths/lifts up to 1.5M measured from the ground level, including dressing/trimming the sides, leveling of bottoms, manual dewatering, removing rank vegetation, backfilling in layers not more than 200 mm thickness, watering, consolidating, compacting to achieve not less than 97% Modified Proctor density conforming to relevant IS, stacking in measurable heaps for future use within owners space or disposing within an initial lead of 150m as directed, loading, unloading, leveling excluding shoring, strutting etc. complete as directed by Engineer-in-Charge. Note: 1) The rate includes the handling/supporting the existing utilities such as cables, drains, pipes, water mains etc. 2) It also includes</p>				
73	R2-CS-SS-02	<p>Providing, detailing, fabricating and fixing built up sections at desired location using MS Plates of grade Fe 250 as per specifications and approved fabrication drawings (which are to be prepared by Contractor and got approved from Engineer), erecting structural steel members for all heights & at all levels including provision of necessary erection bolts, fixing bolts, nuts, washers, cleats, stiffeners, gussets, base plate, and all necessary operations like preheating as per specifications, straightening, bending, cutting, drilling, grinding, machining if</p>	Mt.	35.00	80216	28,07,560.00

		specified, welding, grinding and removing the welding burr and preparing surface for painting with wire brush cleaning and applying two coats of epoxy red oxide zinc phosphate primer of 30 microns each and two coats of Epoxy Corrosion Resistant Enamel paint of 30 microns after fabrication including touching up with spray painting after erection etc complete as directed by Engineer In Charge.				
74	R2-SWD-157	Extra for pumping out water from trenches by 10 H.P. pump per shift of 8hrs.	Nos	1440.00	2394.00	34,47,360.00
75	R2-SWD-153-A	Constructing cofferdam of puddle bags with clay etc. as specified & as directed by Engineer-in-Charge.	Cum	72.00	5282.00	3,80,304.00
76	R2-RW-5-43	P/L hot Premix Dense bituminous macadam with 4.50% bitumen content of grade VG-40 to the required line, level and camber rolling with 10/12 M.T.power, vibratory roller & sensor paver etc. complete as specified and as directed to thickness of 65 mm. with antistripping agent at 1%by weight of bitumen using grading II of "MORTH" (As per prevailing MCGM specifications for Roadworks clause no.354)	Sqm	150.00	586.00	87,900.00
77	R2-RW-5-63	P/L mastic asphalt 40 mm thick with 10/20 grade bitumen including producing the same at computerised batch mix plant, transporting the same to site by means of mastic cookers, laying the same with mastic paver and including all necessary tools, labours & barricading, spreading of aggregates as antiskid measures by means over newly laid	Sqm	150.00	1660.00	2,49,000.00

		mastic				
78	R2-RW-5-23	Providing and applying TACK COAT with CATIONIC BITUMEN EMULSION (RS) @ 0.2 to 0.25 Kg. of Sq.mt over prepared surface to receive bituminous mix by applying TACK COAT with mechanical spray bitumen, including cleaning of road surface etc. completed, as directed For NORMAL BITUMINOUS SURFACES & the tack coat shall be left to cure until all the volatiles have evaporated before any subsequent construction is started, which is indicated by change in colour from brown to black (As per prevailing MCGM specifications for Roadworks Clause No. 314, curing as per 314.3.4)	Sqm	150.00	33.00	4,950.00
						33,99,12,418.10
					Say	33,99,12,418.00

SECTION 9
**GENERAL CONDITIONS OF
CONTRACT**

General Conditions of Contract

A. General

1. Definitions

1.1 Terms which are defined in the Contract Data are not also defined in the Conditions of Contract but keep their defined meanings. Capital initials are used to identify defined terms.

The “Contract” shall mean the tender and acceptance thereof and the formal agreement if any, executed between the Contractor, Commissioner and the Corporation together with the documents referred to therein including these conditions and appendices and any special conditions, the specifications, designs, **drawings**, price schedules, bills of quantities and schedule of rates. All these documents taken together shall be deemed to form one Contract and shall be complementary to one another.

The Contract Data defines the documents and other information which comprise the Contract.

The “Contractor” shall mean the individual or firm or company whether incorporated or not, whose tender has been accepted by the employer and the legal successor of the individual or firm or company, but not (except with the consent of the Employer) any assignee of such person.

The Bidder is a person or corporate body who has desired to submit Bid to carry out the Works, including routine maintenance till the tender process is concluded.

The Contractor's Bid is the completed bidding document submitted by the Contractor to the Employer.

The “Contract Sum” means the sum named in the letter of acceptance including Physical contingencies subject to such addition thereto or deduction there-from as may be made under the provisions hereinafter contained.

Note : The contract sum shall include the following –

- Ñ In the case of percentage rate contracts the estimated value of works as mentioned in the tender adjusted by the Contractor's percentage.
- Ñ In the case of item rate contracts, the cost of the work arrived at after finalization of the quantities shown in schedule of items / **quantities** by the item rates quoted by the tenderers for various items and summation of the extended cost of each item.
- Ñ In case of lump sum contract, the sum for which tender is accepted.
- Ñ Special discount / rebate / trade discount offered by the tenderer if any and accepted by the Corporation.
- Ñ Additions or deletions that are accepted after opening of the tenders.

The “Contract Cost” means the Contract Sum plus Price Variation. This cost shall be included in the letter of acceptance.

A Defect is any part of the Works not completed in accordance with the Contract.

The Defects Liability Certificate is the **certificate** issued by the Engineer, after the Defect Liability Period has ended and upon correction of Defects by the Contractor.

Drawings means all the drawings, calculations and technical information of a like nature provided by the Engineer to the Contractor under the Contract and all drawings, calculations, samples, patterns, models, operation & maintenance manual and other technical information of like nature submitted by the Contractor and approved by the Engineer.

The Authority shall mean Municipal Corporation of Greater Mumbai (MCGM)

The “Employer” shall mean the **Municipal Corporation for Greater Mumbai / Municipal Commissioner for Greater Mumbai**, for the time being holding the said office and also his successors and shall also include all “Additional Municipal Commissioners, Director (Engineering Services & Projects)” and the Deputy Municipal Commissioner, to whom the powers of Municipal Commissioner, have been deputed under Section 56 and 56B of the Mumbai Municipal Corporation Act.

The Engineer in-charge shall mean the Executive Engineer in executive charge of the works and shall include the superior officers of the Engineering department i.e. Dy.Ch.Eng/Ch.Eng. and shall mean and include all the successors in MCGM

The Engineer's Representative shall mean the Assistant Engineer, Sub. Engineer/Jr. Engineer in direct charge of the works and shall include Sub Eng./ Jr. Eng of Civil section/ Mechanical section/ Electrical section appointed by MCGM.

The “Engineer” shall mean the City Engineer / the Hydraulic Engineer / the Chief Engineer / the Special Engineer, appointed for the time being or any other officer or officers of the Municipal Corporation who may be authorized by the commissioner to carry out the functions of the City Engineer / the Hydraulic Engineer / the Chief Engineer / the Special Engineer or any other competent person appointed by the employer and notified in writing to the Contractor to act in replacement of the Engineer from time to time.

Contractor’s Equipment means all appliances and things of whatsoever nature required for the execution and completions of the Works and the remedying of any defects therein, but does not include plant material or other things intended to form or forming part of the Permanent Works.

The Initial Contract Price is the Contract Price listed in the Employer's Letter of Acceptance.

The Intended Completion Date is the date on which it is intended that the Contractor shall complete the construction works. The Intended Completion Date is specified in the Contract Data. The Intended Completion Date may be revised only by the Engineer by issuing an extension of time.

Materials are all supplies, including consumables, used by the Contractor for incorporation in the Works and works of routine maintenance.

Plant is any integral part of the Works that shall have a mechanical, electrical, electronic, chemical, or biological function.

Routine Maintenance is the maintenance of activities of the completed structure for five years as specified in the Contract Data.

The “Site” shall mean the land and other places including water bodies more specifically mentioned in the special conditions of the tender, on, under in or through which the permanent works or temporary

works are to be executed and any other lands and places provided by the Municipal Corporation for working space or any other purpose as may be specifically designated in the contract as forming part of the site.

Site Investigation Reports are those that were included in the bidding documents and are reports about the surface and subsurface conditions at the Site.

“Specification” shall mean the specification referred to in the tender and any modification thereof or addition or deduction thereto as may from time to time be furnished or approved in writing by the Engineer.

The Start Date/Commencement Date is given in the Contract Data. It is the date when the Contractor shall commence execution of the Works. It does not necessarily coincide with any of the Site Possession Dates.

A Nominated Sub-Contractor is a person or corporate body who has a Contract with the Contractor to carry out a part of the construction work and/or routine maintenance in the Contract, which includes work on the Site.

Temporary Works are works designed, constructed, installed, and removed by the Contractor that are needed for construction or installation of the Works.

Variation means a change to the:-

- i) Specification and /or Drawings (if any) which is instructed by the Employer.
- ii) Scope in the Contract which is instructed by the Employer.
- iii) Price in the Contract which is instructed by the Employer.

The Works, as defined in the Contract Data, are what the Contract requires the Contractor to construct, install, maintain, and turn over to the Employer. Routine maintenance is defined separately.

Jurisdiction: In case of any claim, dispute or difference arising in respect of a contract, the cause of action thereof shall be deemed to have arisen in Mumbai and all legal proceedings in respect of any claim, dispute or difference shall be instituted in a competent court in the City of Mumbai only.

2. Interpretation

In interpreting these Conditions of Contract, singular also means plural, male also means female or neuter, and the other way around. Headings have no significance. Words have their normal meaning under the language of the Contract unless specifically defined. The Engineer will provide instructions clarifying queries about these Conditions of Contract.

If sectional completion is specified in the Contract Data, references in the Conditions of Contract to the Works, the Completion Date, and the Intended Completion Date apply to any Section of the Works (other than references to the Completion Date and Intended Completion Date for the whole of the Works).

The documents forming the Contract shall be interpreted in the following documents: (1) Agreement, (2) Letter of Acceptance, (3) Notice to Proceed with the Work, (4) Contractor's Bid, (5) Contract Data, (6) Special Conditions of Contract Part (7) General Conditions of Contract Part I, (8) Specifications, (9) Drawings, (10) Bill of Quantities, and (11) Any other document listed in the

Contract Data.

3. **Engineer's Decisions**

3.1 Except where otherwise specifically stated, the Engineer will decide contractual matters between the Employer and the Contractor in the role representing the Employer. However, if the Engineer is required under the rules and regulations and orders of the Employer to obtain prior approval of some other authorities for specific actions, he will so obtain the approval, before communicating his decision to the Contractor.

3.2 Except as expressly stated in the Contract, the Engineer shall not have any authority to relieve the Contractor of any of his obligations under the contract.

4. **Delegation**

4.1 The Engineer, with the approval of the Employer, may delegate any of his duties and responsibilities to other person(s), except to the Adjudicator, after notifying the Contractor, and may cancel any delegation after notifying the Contractor.

5. **Communications**

All certificates, notices or instructions to be given to the Contractor by Employer/ Engineer shall be sent on the address or contact details given by the Contractor of Bid. The address and contact details for communication with the Employer/ Engineer shall be as per the details given in Contract Data. Communications between parties that are referred to in the conditions shall be in writing. The Notice sent by facsimile (fax) or other electronic means shall be effective on confirmation of the transmission. The Notice sent by Registered post or Speed post shall be effective on delivery or at the expiry of the normal delivery period as undertaken by the postal service.

6. **Subcontracting**

6.1 Unless specifically mentioned in the contract subletting will not be allowed. Subletting, where otherwise provided by the contract shall not be more than 25% of the contract price.

6.2 The Contractor shall not be required to obtain any consent from the Employer for:

- a) the sub-contracting of any part of the Works for which the Subcontractor is named in the Contract;
- b) The provision for labour, or labour component.
- c) The purchase of Materials which are in accordance with the standards specified in the Contract.

6.3 Beyond what has been stated in clauses 6.1 and 6.2, if the Contractor proposes sub contracting any part of the work during execution of the Works, because of some unforeseen circumstances to enable him to complete the Works as per terms of the Contract, the Employer will consider the following before according approval:

- a) The Contractor shall not sub-contract the whole of the Works.
- b) The permitted subletting of work by the Contractor shall not establish any contractual

relation- ship between the sub-contractor and the MCGM and shall not relieve the Contractor of any responsibility under the Contract.

6.4 The Engineer should satisfy himself before recommending to the Employer whether

- a) the circumstances warrant such sub-contracting; and
- b) the sub-Contractor so proposed for the Work possesses the experience, qualifications and equipment necessary for the job proposed to be entrusted to him.

7. Other Contractors

7.1 The Contractor shall cooperate and share the Site with other Contractors, public authorities, utilities, and the Employer between the dates given in the Schedule of Other Contractors, as referred to in the Contract Data. The Contractor shall also provide facilities and services for them as described in the Schedule. The Employer may modify the Schedule of Other Contractors, and shall notify the Contractor of any such modification.

7.2 The Contractor should take up the works in convenient reaches as decided by the Engineer to ensure there is least hindrance to the smooth flow and safety of traffic including movement of vehicles and equipment of other Contractors till the completion of the Works.

8. Personnel

8.1 The Contractor shall employ for the construction work and routine maintenance the key personnel including technical personnel named in the Contract Data or other personnel approved by the Engineer. The Engineer will approve any proposed replacement of technical personnel only if their relevant qualifications and abilities are substantially equal to those of the personnel stated in the Contract Data.

8.2 The Contractor's personnel shall appropriately be qualified, skilled and experienced in their respective trades or occupations. The Engineer shall have authority to remove, or cause to be removed, any person employed on the site or works, who carries out duties incompetently or negligently and persists in any conduct which is prejudicial to safety, health or the protection of the environment.

8.3 If the Engineer asks the Contractor to remove a person who is a member of the Contractor's staff or work force, stating the reasons, the Contractor shall ensure that the person leaves the Site within seven days and has no further connection with the Works in the Contract.

8.4 The Contractor shall not employ any retired Gazetted officer who has worked in the Engineering Department of the MCGM /State Government and has either not completed two years after the date of retirement or has not obtained MCGM/State Government's permission to employment with the Contractor.

9. Employer's and Contractor's Risks

9.1 The Employer carries the risks which this Contract states are Employer's risks, and the Contractor carries the risks which this Contract states are Contractor's risks.

10. Employer's Risks

10.1 The Employer is responsible for the excepted risks which are (a) in so far as they directly affect the execution of the Works in the Employer's country, the risks of war, invasion, act of foreign enemies, rebellion, revolution, insurrection or military or usurped power, civil war, riot, commotion or disorder (unless restricted to the Contractor's employees) and contamination from any nuclear fuel or nuclear waste or radioactive toxic explosive, or (b) a cause due solely to the design of the Works, other than the Contractor's design.

11. Contractor's Risks

11.1 All risks of loss of or damage to physical property and of personal injury and death which arise during and in consequence of the performance of the Contract other than the excepted risks, referred to in clause 11.1, are the responsibility of the Contractor.

12. Insurance

12.1 The Contractor at his cost shall provide, in the joint names of the Employer and the Contractor, insurance cover from the Start Date to the end of Defects Liability Period, in the amounts and deductibles stated in the Contract Data for the following events which are due to the Contractor's risks:

- a) Loss of or damage to the Works, Plant and Materials;
- b) Loss of or damage to Equipment;
- c) Loss of or damage to property (other than the Works, Plant, Materials, and Equipment) in connection with the Contract; and
- d) Personal injury or death.

12.2 Insurance policies and certificates for insurance shall be delivered by the Contractor to the Engineer for the Engineer's approval before the Start Date. All such insurance shall provide for compensation to be payable in the types and proportions of currencies required to rectify the loss or damage incurred.

12.3 Alterations to the terms of insurance shall not be made without the approval of the Engineer.

12.4 Both parties shall comply with any conditions of the insurance policies.

12.5 If the Contractor does not provide any of the policies and certificates required, the Employer may affect the insurance which the Contractor should have provided and recover the premiums the Employer has paid, from payments otherwise due to the Contractor or if no payment is due, the payment of premiums shall be debt due.

13. Site Investigation Reports

13.1 The Contractor, in preparing the Bid, may rely, at his own risk, on any Site Investigation Reports referred to in the Contract Data, supplemented by any other information available to him, before submitting the bid.

14. **Queries about the Contract Data**

14.1The Engineer will clarify queries on the Contract Data.

15. **Contractor to Construct the Works and Undertake Maintenance (if specified in the tender)**

15.1 The Contractor shall construct, and install and maintain the Works in accordance with the Specifications and Drawings and as per instructions of the Engineer.

15.2 The Contractor shall construct the works with intermediate technology, i.e., by manual means with medium input of machinery required to ensure the quality of works as per specifications. The Contractor shall deploy the equipment and machinery as required in the contract.

15.3 The Contractor shall take all reasonable steps to protect the environment on and off the Site and to avoid damage or nuisance to persons or to property of the public or others resulting from pollution, noise or other causes arising as a consequence of his methods of operation.

During continuance of the contract, the Contractor and his sub-contractors shall abide at all times by all existing enactments on environmental protection and rules made there under, regulations, notifications and byelaws of the State or Central Government, or local authorities and any other law, bye-law, regulations that may be passed or notification that may be issued in future by the State or Central Government or the local authority. Salient features of some of the major laws that are applicable are given below:

- The Water (Prevention and Control of Pollution) Act, 1974, this provides for the prevention and control of water pollution and the maintaining and restoring of wholesomeness of water. 'Pollution' means such contamination of water or such alteration of the physical, chemical or biological properties of water or such discharge of any sewage or trade effluent or of any other liquid, gaseous or solid substance into water (whether directly or indirectly) as may, or is likely to, create a nuisance or render such water harmful or injurious to public health or safety, or to domestic, commercial, industrial, agricultural or other legitimate uses, or to the life and health of animals or plants or of aquatic organisms.
- The Air (Prevention and Control of Pollution) Act, 1981, this provides for prevention, control and abatement of air pollution. 'Air Pollution' means the presence in the atmosphere of any 'air pollutant', which means any solid, liquid or gaseous substance (including noise) present in the atmosphere in such concentration as may be or tend to be injurious to human beings or other living creatures or plants or property or environment.
- The Environment (Protection) Act, 1986, this provides for the protection and improvement of environment and for matters connected therewith, and the prevention of hazards to human beings, other living creatures, plants and property. 'Environment'

includes water, air and land and the inter- relationship which exists among and between water, air and land, and human beings, other living creatures, plants, micro-organism and property.

- The Public Liability Insurance Act, 1991, This provides for public liability insurance for the purpose of providing immediate relief to the persons affected by accident occurring while handling hazardous substances and for matters connected herewith or incidental thereto. Hazardous substance means any substance or preparation which is defined as hazardous substance under the Environment (Protection) Act 1986, and exceeding such quantity as may be specified by notification by the Central Government.

16. The Works and Routine Maintenance to be completed by the Intended Completion Date.

16.1 The Contractor may commence execution of the Works on the Start Date and shall carry out the Works and Routine Maintenance, if specified in the tender, in accordance with the Programme submitted by the Contractor, as updated with the approval of the Engineer, and complete them by the Intended Completion Date.

17. Approval by the Engineer

17.1 The Contractor shall submit Specifications and Drawings showing the proposed Temporary Works to the Engineer, who is to approve them if they comply with the Specifications and Drawings.

17.2 The Contractor shall be responsible for design and safety of Temporary Works.

17.3 The Engineer's approval shall not alter the Contractor's responsibility for design and safety of the Temporary Works.

17.4 The Contractor shall obtain approval of third parties to the design of the Temporary Works, where required.

17.5 All Drawings prepared by the Contractor for the execution of the temporary or permanent Works, are subject to prior approval by the Engineer before their use.

18. Safety

18.1 The Contractor shall be responsible for the safety of all activities on the Site. He shall comply with all applicable safety requirements and take care of safety of all persons entitled to be on the site and the works. He shall use reasonable efforts to keep the site and the works, both during construction and maintenance, clear of unnecessary obstruction so as to avoid danger to the persons and the users.

- Workers employed on mixing asphaltic materials, cement and lime mortars shall be provided with protective footwear and protective goggles.
- Stone breaker shall be provided with protective goggles and protective clothing and seated at sufficiently safe intervals.

- The area should be barricaded or cordoned off by suitable means to avoid mishaps of any kind. Power warning signs should be displayed for the safety of the public whenever cleaning works are undertaken during night or day.
- The workers engaged for cleaning the manholes/sewers should be properly trained before allowing working in the manhole.

18.2 Safety Programs:-

- I. Have adequate safety supervision in place to ensure that safety programs set up by the firms/agencies are in compliance with prevalent laws and regulations.
- II. Review safety programs developed by each of the trade firms, prepare and submit a comprehensive safety program.
- III. Monitor day to day implementation of safety procedures.

18.3 First Aid Facilities: -

- i. At every work place there shall be provided and maintained, so as to be easily accessible during working hours, first-aid boxes at the rate of not less than one box for 150 contract labour or part thereof ordinarily employed.
- ii. The first-aid box shall be distinctly marked with a red cross on white back ground.
- iii. Adequate arrangements shall be made for immediate recoupment of the equipment when necessary.
- iv. Nothing except the prescribed contents shall be kept in the First-aid box.
- v. The first-aid box shall be kept in charge of a responsible person who shall always be readily available during the working hours of the work place.
- vi. A person in charge of the First-aid box shall be a person trained in First-aid treatment, in the work places where the number of contract labour employed is 150 or more.

19. Discoveries

- 19.1** Anything of historical or other interest or of significant value unexpectedly discovered on the Site shall be the property of the Employer. The Contractor shall notify the Engineer of such discoveries and carry out the Engineer's instructions for dealing with them.

20. Possession of the Site

- 20.1** The Employer shall handover complete or part possession of the site to the Contractor 7 days in advance of construction programme. At the start of the work, the Employer shall handover the possession of at-least 75% of the site free of all encumbrances, the remaining 25 % of the possession as per contractor's constructionprogramme.

21. Access to the Site

21.1 The Contractor shall allow access to the Site and to any place where work in connection with the Contract is being carried out, or is intended to be carried out to the Engineer and any person/persons/agency authorized by: a. The Engineer b. The Employer or authorized by the Employer.

22. Instructions

22.1 The Contractor shall carry out all instructions of the Engineer, which comply with the applicable laws where the Site is located.

22.2 The Contractor shall permit the appointed and/or authorized persons to inspect the Site and/or accounts and records of the Contractor and its subcontractors relating to the performance of the Contract, and to have such accounts and records audited by auditors appointed, if so required. The Contractor's attention is invited to Clause of 'Fraud and Corruption', which provides, inter alia, that acts intended to materially impede the exercise of the inspection and audit rights provided for under the Clause & constitute a obstructive practice subject to contract termination.

22.3 Engineer to have power to issue further drawings or instructions:

The Engineer shall have the power and authority from time to time and at all times to make and issue such further drawings and to give such further instructions and directions as may appear to him necessary or proper for the guidance of the contractor and the good and sufficient execution of the works according to terms of the specifications and Contractor shall receive, execute, obey and be bound by the same, according to the true intent and meaning thereof, as fully and effectually as though the same had accompanied or had been mentioned or referred to in the specification, and the Engineer may also alter or vary the levels or position of nature of works contemplated by the specifications, or may order any of the works contemplated thereby to be omitted, with or without the substitution of any other works in lieu thereof, or may order any work or any portion of work executed or partially executed, to be removed, changed or altered, added if needful, may order that other works shall be substituted instead thereof and difference of expense occasioned by any such diminution or alteration so ordered and directed shall be added to or deducted from the amount of this Contract, as provided under condition no.10(a) hereinafter.

No work which radically changes the original nature of the Contract shall be ordered by the Engineer and in the event of any deviation being ordered which in the opinion of the Contractor changes the original nature of Contract he shall nevertheless carry it out and disagreement as to the nature of the work and the rate to be paid therefore shall be resolved in accordance with condition no.13d.

The time for completion of the Works, shall be in even of any deviations resulting in additional cost over the contract price being ordered, be extended or reduced reasonably by the Engineer. The Engineer's decision in this case shall be final.

B. Time Control

23. Programme

23.1 Within the time stated in the Contract Data, the Contractor shall submit to the Engineer for approval a Programme, including Environment Management Plan showing the general methods, arrangements, order, and timing for all the activities in the Works, along with monthly cash flow forecasts for the construction of works.

After the completion of the construction works, the programme for the Routine Maintenance Work, showing the general methods, arrangements, order and timing for all the activities involved in the Routine Maintenance will also be submitted by the Contractor to the Engineer for approval if specified in the tender. The programme for Routine Maintenance will be submitted in each year for the period of Maintenance.

23.2 The Contractor shall submit the list of equipment and machinery being brought to site, the list of key personnel being deployed, the list of machinery/ equipment's being placed in field laboratory and the location of field laboratory along with the Programme. The Engineer shall cause these details to be verified at each appropriate stage of the programme.

23.3 An update of the Programme shall be a programme showing the actual progress achieved on each activity and the effect of the progress achieved on the timing of the remaining Works, including any changes to the sequence of the activities.

23.4 The Contractor shall submit to the Engineer for approval an updated Programme at intervals no longer than the period stated in the Contract Data. If the Contractor does not submit an updated Programme within this period, the Engineer may withhold the amount stated in the Contract Data from the next payment certificate and continue to withhold this amount until the next payment after the date on which the overdue Programme has been submitted.

23.5 The Engineer's approval of the Programme shall not alter the Contractor's obligations. The Contractor may revise the Programme and submit it to the Engineer again at any time. A revised Programme shall show the effect of Variations and Compensation Events.

24. Extension of Time In Contracts:

Subject to any requirement in the contract as to completion of any portions or portions of the works before completion of the whole, the contractor shall fully and finally complete the whole of the works comprised in the contract (with such modifications as may be directed under conditions of this contract) by the date entered in the contract or extended date in terms of the following clauses:

a) Extension attributable to MCGM

- i. Extension Due To Modification:** If any modifications have been ordered which in the opinion of the Engineer have materially increased the magnitude of the work, then such

extension of the contracted date of completion may be granted as shall appear to the Engineer to be reasonable in the circumstances, provided moreover that the Contractor shall be responsible for requesting such extension of the date as may be considered necessary as soon as the cause thereof shall arise and in any case **should not be less than 30 days before the expiry of the date fixed for completion of the works.**

- ii. **Extension For Delay Due To MCGM:** In the event of any failure or delay by the MCGM to hand over the Contractor possession of the lands necessary for the execution of the works or to give the necessary notice to commence the works or to provide the necessary drawings or instructions or any other delay caused by the MCGM due to any other cause whatsoever, then such failure or delay shall in no way affect or vitiate the contract or alter the character thereof or entitle the contractor to damages or compensation therefore, but in any such case, the MCGM may grant such extension(s) of the completion date as may be considered reasonable.

Note: For extension of time period as governed in (i) and (ii) above, any modifications in design/drawings, specifications, quantities shall be needed to be justified with recorded reasons with approval of Ch. Eng. for not anticipating the same while preparing estimates and draft tender.

- b) **Extension of Time For Delay Due To Contractor:** The time for the execution of the work or part of the works specified in the contract documents shall be deemed to be the essence of the contract and the works must be completed no later than the date(s) / the programme for completion of work as specified in the contract. If the contractor fails to complete the works within the time as specified in the contract for the reasons other than the reasons specified in above as (a.i) and (a.ii), the MCGM may, if satisfied that the works can be completed by the contractor within reasonable short time thereafter, allow the contractor for further extension of time as the Engineer may decide. On such extension the MCGM will be entitled without prejudice to any other right and remedy available on that behalf, to recover the compensation as governed by Clause 8(e) of GCC.

For the purpose of this Clause, the contract value of the works shall be taken as value of work as per contract agreement including any supplementary work order/contract agreement issued

Further, competent authority while granting extension to the currency of contract under Clause (b) of as above may also consider levy of penalty, as deemed fit based on the merit of the case. Also, the reasons for granting extension shall be properly documented

25. Delays Ordered by the Engineer

- 25.1 The Engineer may instruct the Contractor to delay the start or progress of any activity within the Works. Delay/delays totaling more than 30 days will require prior written approval of the DMC/AMC.

26. Management Meetings

- 26.1 The Engineer may require the Contractor to attend a management meeting. The business of a

management meeting shall be to review the plans for progress of the Works.

- 26.2 The Engineer shall record the business of management meetings and provide copies of the record to those attending the meeting. The responsibility of the parties for actions to be taken shall be decided by the Engineer either at the management meeting or after the management meeting and stated in writing to all those who attended the meeting.

C. Quality Control

27.

27.1 Work to be open to Inspection and Contractor or Responsible agent to be present

All works under or in course of execution or executed in pursuance of the contract shall at all times be open to the inspection and supervision of the Eng-in-charge and his subordinates and the contractor shall at all times during the usual working hours, at all other times, during the usual working hours and at all other times at which reasonable notice of the intention of the Eng-in-charge and his subordinates to visit the works shall have been given to the contractor, either himself be present to receive orders and instruction or have responsible agent duly accredited in writing present for that purpose. Order given to the contractors' duly authorized agent shall be considered to have the same force and effect as if they had been given to the contractor himself.

27.2 Notice To Be Given Before Work Is Covered Up

The contractor shall give not less than ten days' notice in writing to the Eng-In-Charge or his subordinate in-charge of the work before covering up or otherwise placing beyond the reach of measurement any work in order that the same may be measured and correct dimension thereof taken before the same is so covered up or placed beyond the reach of measurements and shall not cover up or place beyond the reach of measurement any work without the consent in writing of the Eng-In-Charge or his subordinate in-charge of the work, and if any work shall be covered up or placed beyond the reach of measurement, without such notice having been given or consent obtained the same shall be uncovered at the contractors expenses, and in default thereof no payment or allowance shall be made for such work or for the materials with which the same was executed.

27.3 Works to be executed in accordance with specifications / drawings / orders etc. :

The contractor shall execute the whole and every part of the work the most substantial and workman like manner and both has regards material and every other respect in strict accordance with specifications. The contractor shall also confirm exactly, fully and faithfully to the designs, drawings and instructions in writing relating to the work signed by the Engineer In-charge and lodged in his office and to which the contractor shall be entitled to have access for the purpose of inspection at such office, or on the site or work during office hours. The contractor shall be entitled to receive three sets of contract drawings and working drawings as well as one certified copy of the accepted tender along with the work order free of cost.

27.4 Ready Mix Concrete/ Asphalt Mix

- (i) The contractor shall have to arrange Ready Mix concrete (RMC)/Asphalt from RMC/ASPHALT producing plants registered with MCGM.
- (ii) The contractor shall, within 7 days of award of the work, submit a list of at least three RMC/Asphalt producers with details of such plants including details and number of transit, mixers & pumps etc. to be deployed indicating name of owner/company, its location, capacity, and technical establishment.

The Engineer-in-charge will reserve right to inspect at any stage and reject the concrete if he is not satisfied about quality of product at the user's end.

- (iii) The Engineer-in-charge reserves the right to exercise control over the:-
 - a) Calibration check of the RMC/Asphalt plant.
 - b) Weight and quantity check on the ingredients, water and admixtures added for batch mixing for RMC plants
 - c) Time of mixing of concrete/grade of asphalt.
 - d) Testing of fresh concrete/asphalt mix, recording of results and declaring the mix fit or unfit for use. This will include continuous control on the work ability during production and taking corrective action, if required.
 - e) For exercising such control, the Engineer-in-charge shall periodically depute his authorized representative at the RMC/Asphalt plant. It shall be responsibility of the contractor to ensure that all necessary equipment, manpower & facilities are made available to Engineer-in-charge and or his authorized representative at RMC/Asphalt plant.
 - f) All required relevant records of RMC/Asphalt mix shall be made available to the Engineer-in-charge or his authorized representative. Engineer-in-charge shall, as required, specify guidelines & additional procedures for quality control & other parameters in respect of material production& transportation of concrete mix which shall be binding on the contractor & the RMC/Asphalt plant. Only concrete as approved in design mix by Engineer- in-charge shall be produced in RMC plant and transported to the site.
 - g) The contractor shall have to produce a copy of challan receipts/SCADA reports/VTS reports as issued by the RMC/Asphalt plant as a documentary proof in lieu of supply of RMC/Asphalt mix before releasing payment.

28. Identifying Defects

28.1 The Engineer shall check the Contractor's work and notify the Contractor of any Defects that are found. Such checking shall not affect the Contractor's responsibilities. The Engineer may instruct the Contractor to search for a Defect and to uncover and test any work that the Engineer considers may have a Defect.

28.2 The Contractor shall permit the Employer's technical person(s) to check the Contractor's work and notify the Engineer and Contractor if any defects that are found.

29. Tests

29.1 For carrying out mandatory tests as prescribed in the specifications, the Contractor shall establish field laboratory at the location decided by Engineer. The field laboratory will have minimum of equipment's as specified in the Contract Data. The contractor shall be solely responsible for:

- a. Carrying out the mandatory tests prescribed in the Specifications, and
- b. For the correctness of the test results, whether performed in his laboratory or elsewhere.

29.2 If the Engineer instructs the Contractor to carry out a test not specified in the Specification/ Quality Assurance Handbook to check whether any work has a Defect and the test shows that it does, the Contractor shall pay for the test and any samples. If there is no defect, the test shall be a compensation event.

When required by the Engineer-in-charge the contractor(s) shall supply for the purpose of testing samples of all materials proposed to be used in the works. Samples submitted either to govern bulk supplies or required for testing before use shall be in suitable packages to contain them and shall be provided free of charge by the contractor. The cost of testing shall be borne by the contractor even if the result of the sample confirm or do not confirm to the relevant BIS code specifications.

- i. All expenditure required to be incurred for taking the samples conveyance, packing shall be borne by the contractor himself.
- ii. The failed material shall be removed from the site by the contractor at his own cost within a week time of written order of the Engineer-in-charge.

29.3 Setting of Site Laboratories (Applicable for works costing more than Rs, 5 Crores:

Contractors shall set up a laboratory at site before commencement of work at their cost for performing various tests and at least the following machines and equipment shall be provided therein –

- 1) Set of Sieves as per I.R.C. /I.S.
- 2) Compressive Testing Machine(For new works)
- 3) Oven, Electrically Operated
- 4) Weighing Balance (20 kg capacity)
- 5) 3 m straight edge
- 6) Sieve shaker
- 7) First Aid Box
- 8) Measuring Jar (for silt content)
- 9) Other Machines/apparatus as may be directed by the Engineer
- 10) Vernier Caliber

11) Level / Theodolite

All the test records shall be maintained in the site office and made available as and when required. The laboratory must be established within 15 days from the date of receipt of the orders from Engineer In charge. On failure to do so, a penalty of Rs 1000/- per day shall be imposed.

The contractor shall install testing equipment at site. The contractor shall ensure and certify the calibration of the equipment so installed and shall maintain the same in working order throughout the period of construction. The contractor shall also provide necessary technically qualified experienced trained staff for carrying out such tests for using such equipment. The tests shall be carried out under the supervision of the Engineer-in-charge. The calibration shall be checked every twelve months as directed by Engineer-in-charge.

30. **Correction of Defects noticed during the Defects Liability Period.**

- a) The Engineer shall give notice to the Contractor of any Defects before the end of the Defects Liability Period, which begins at Completion and ends after five years. The Defects Liability Period shall be extended for as long as Defects remain to be corrected.
- b) Every time notice of Defect/Defects is given, the Contractor shall correct the notified Defect/Defects within the duration of time specified by the Engineer's notice.
- c) The Engineer may issue notice to the Contractor to carry out removal of defects or deficiencies, if any, noticed in his inspection, or brought to his notice. The Contractor shall remove the defects and deficiencies within the period specified in the notice and submit to the Engineer a compliance report.

31. **Uncorrected Defects and Deficiencies**

- 31.1** If the Contractor has not corrected a Defect pertaining to the Defect Liability Period under clause and deficiencies in maintenance, to the satisfaction of the Engineer, within the time specified in the Engineer's notice, the Engineer will assess the cost of having the Defect or deficiency corrected, and the Contractor shall pay this amount, on correction of the Defect or deficiency by another agency.

C. Cost Control

32. **Variations**

The Engineer shall, having regard to the scope of the Works and the sanctioned estimated cost, have power to order, in writing, Variations within the scope of the Works he considers necessary or advisable during the progress of the Works. Such Variations shall form part of the Contract and the Contractor shall carry them out and include them in updated Programmes produced by the Contractor. Oral orders of the Engineer for Variations, unless followed by written confirmation, shall not be taken into account.

33. **Payments for Variations**

33.1 If rates for Variation items are specified in the Bill of Quantities, the Contractor shall carry out such work at the same rate.

33.2 The rate for Extra/Excess shall be governed by clause 10.A of Standard General Condition of Contract.

34. **Cash Flow Forecasts**

When the Programme is updated, the Contractor shall provide the Engineer with an updated cash flow forecast.

35. **Payment Certificates**

The payment to the Contractor will be as follows for construction work:

- a) A bill shall be submitted by the Contractor monthly or before the date fixed by the Engineer In-charge for all works executed in the previous month, and the Engineer In-charge shall take or cause to be taken requisite measurement for the purpose of having the same verified and the claim, so far as it is admissible, shall be adjusted, if possible, within 10 days from the presentation of the bill. If the contractor does not submit the bill within the time fixed as aforesaid, the Engineer In-charge may depute a subordinate to measure up the said work in the presence of the contractor or his duly authorized agent whose counter signature to the measurement list shall be sufficient warrant, and Engineer In-Charge may prepare a bill from such list which shall be binding on the contractor in all respects.
- b) The Engineer shall check the Contractor's fortnightly/monthly statement within 14 days and certify the amount to be paid to the Contractor.
- c) The value of work executed shall be determined, based on measurements by the Engineer.
- d) The value of work executed shall comprise the value of the quantities of the items in the Bill of Quantities completed.
- e) The value of work executed shall also include the valuation of Variations and Compensation Events.
- f) The Engineer may exclude any item certified in a previous certificate or reduce the proportion of any item previously certified in any certificate in the light of later information. (g) The contractor shall submit all bills on the printed forms at the office of Engineer In-charge. The charges to be made in the bills shall always be entered at the rates specified in tender.

36. **Payments**

36.1 Payments shall be adjusted for deductions for advance payments, retention, security deposit, other recoveries in terms of the Contract and taxes at source, as applicable under the law. The Employer shall pay the Contractor the amounts certified by the Engineer within 15 days of the date of each certificate.

36.2 All sums payable by a contractor by way of compensation under any of these conditions, shall be considered as a reasonable compensation to be applied to the use of MCGM without

reference to the actual loss or damage sustained and whether any damage has or has not been sustained.

36.3 No payment shall be made for any work estimated to cost less than Rupees One Thousand till after the whole of work shall have been completed and the certificate of completion given. But in the case of works estimated to cost more than Rs. One Thousand, the contractor shall on submitting a monthly bill therefore be entitled to receive payment proportionate to the part of the work than approved and passed by the Engineer In-charge, whose certificate of such approval and passing of the sum so payable shall be final and conclusive against the contractor. All such intermediate payments shall be regarded as payments by way of advance against the final payments only and not as payments for work actual done and completed and shall not preclude the Engineer In-charge from requiring any bad, unsound, imperfect or unskillful work to be removed or taken away and reconstructed or re-erected nor shall any such payment be considered as an admission of the due performance of the contract or any part thereof in any respect or the offering of any claim not shall it conclude, determine or effect in any other way, the powers of the Engineer In-charge as to the final settlement and adjustment of the accounts or otherwise, or in any other way vary or effect the contract. The final bill shall be submitted by the Contractor within one month of the date fixed for the completion of the work otherwise the Engineer In-charge's certificate of the measurements and of the total amount payable for the work shall be final and binding on all parties.

37. The Contractor shall not be entitled to compensation to the extent that the Employer's interests are adversely affected by the Contractor for not having given early warning or not having cooperated with the Engineer.

38. Tax

G.S.T. and other state levies / cess which are not subsumed under GST will be applicable. The tenderer shall quote inclusive of taxes. It is clearly understood that MCGM will not bear any additional liability towards payment of any Taxes & Duties.

Wherever the Services to be provided by the Tenderer falls under Reverse Charge Mechanism, the Price quoted shall be exclusive of GST, but inclusive of Taxes / Duties / Cess other than GST, if any.

Rates accepted by MCGM shall hold good till completion of work and no additional individual claim shall be admissible on account of fluctuations in market rates; increase in taxes / any other levies / tolls etc. except that payment / recovery for overall market situation shall be made as per price Variation.

“Chapter XXI-Miscellaneous, section 171(1) of GST Act, 2017 governs the ‘Anti Profiteering Measure’ (APM). As per the provision of this section, ‘Any reduction in rate of tax on any supply of goods or services or the benefit of input tax credit shall be passed on to the recipient by way of commensurate reduction in prices’.

Accordingly, the contractor should pass on the complete benefit *accruing to him on account of reduced tax rate or additional input tax credit*, to MCGM.

39. Further, all the provisions of GST Act will be applicable to the tender. **“Currencies**

All payments will be made in Indian Rupees.

40. Liquidated Damages

Both, the Contractor and the Employer have agreed that it is not feasible to precisely estimate the amount of losses due to delay in completion of works and the losses to the public and the economy, therefore, both the parties have agreed that the Contractor shall pay liquidated damages to the Employer and not by way of penalty, at the rate per week or part thereof stated in the Contract Data for the period that the Completion Date is later than the Intended Completion Date. Liquidated damages at the same rates shall be withheld if the Contractor fails to achieve the milestones prescribed in the Contract Data. However, in case the Contractor achieves the next milestone, the amount of the liquidated damages already withheld shall be restored to the Contractor by adjustment in the next payment certificate. The Employer and the contractor have agreed that this is a reasonable agreed amount of liquidated damage. The Employer may deduct liquidated damages from payments due to the Contractor. Payment of liquidated damages shall not affect the Contractor's other liabilities.

41. Cost of Repairs

Loss or damage to the Works or Materials to be incorporated in the Works between the Start Date and the end of the Defects Correction periods shall be remedied by the Contractor at his cost if the loss or damage arises from the Contractor's acts or omissions.

E. Finishing the Contract

42. Completion of Construction and Maintenance

42.1 The Contractor shall request the Engineer to issue a certificate of completion of the construction of the works, and the Engineer will do so upon deciding that the works is completed. This shall be governed as per clause no.8(g) of Standard General Conditions of Contract.

43. Taking Over

43.1 The Employer shall take over the works within seven days of the Engineer issuing a certificate of completion of works. The Contractor shall continue to remain responsible for its routine maintenance during the maintenance period if specified in the contract.

44. Final Account

Final joint measurement alongwith the representatives of the contractor should be taken recorded and signed by the Contractors. Contractors should submit the final bill within 1 month of physical completion of the work.

If the contractor fails to submit the final bill within 1 month, the MCGM staff will prepare the final bill based on the joint measurement within next 3 months.

Engineer's decision shall be final in respect of claims for defect and pending claims against contractors.

No further claims should be made by the Contractor after submission of the final bill and these shall be deemed to have been waived and extinguished. Payment of those items of the bills in respect of which there is no dispute and of items in dispute, for quantities and rates as approved by the Commissioner shall be made within a reasonable period as may be necessary for the purpose of verification etc.

After payment of the final bill as aforesaid has been made, the contractor may, if he so desires, reconsider his position in respect of a disputed portion of the final bills and if he fails to do so within 84 days, his disputed claim shall be dealt with as provided in the contract.

A percentage of the retention money, over and above the actual retention money as indicated below shall be held back from payments till the finalization of final bill to be submitted as per above and will be paid within 30 days of acceptance of the final bill.

Sr.No.	Amount of Contract Cost	Minimum Payable Amount in final bill
1	Upto Rs.5 Crores	Rs.10 Lacs or final bill amount whichever is more
2	Upto Rs.25 Crores	Rs.1 Crore or final bill amount whichever is more
3	Upto Rs.50 Crores	Rs.2 Crore or final bill amount whichever is more
4	Upto Rs.100 Crores	Rs.4 Crore or final bill amount whichever is more
5	More than Rs.100 Crores	Rs.7 Crore or final bill amount whichever is more

The contractor have to submit the bill for the work carried out within 15 days from the date of completion of the work to the respective executing department. If the contractor fails to submit their bills to concerned executing department, penalty or action as shown below will be taken for each delayed bill:-

After 15 days from the date of completion/running bill upto certain date, upto to next 15 days i.e. upto 30 days.	Equal to 5 % of bill amount.
Next 15 days upto 45 days from the date of completion/running bill upto specified date.	Equal to 10 % of bill amount
If not submitted within 45 days from the date of completion/RA Bill	Bill will not be admitted for payment.

45. Operating and Maintenance Manuals

45.1 If "as built" Drawings and/or operating and maintenance manuals are required, the Contractor shall supply them by the dates stated in the Contract Data.

45.2 If the Contractor does not supply the Drawings and/or manuals by the dates stated in the Contract Data, or they do not receive the Engineer's approval, the Engineer shall withhold the amount stated in the Contract Data from payments due to the Contractor.

46. Termination

46.1 The Employer or the Contractor may terminate the Contract if the other party causes a fundamental breach of the Contract.

46.2 Fundamental breaches of Contract shall include, but shall not be limited to, the following:

- a) The Contractor stops work for 30 days when no stoppage of work is shown on the current Programme and the stoppage has not been authorized by the Engineer;
- b) The Contractor is declared as bankrupt or goes into liquidation other than for approved reconstruction or amalgamation;
- c) The Engineer gives Notice that failure to correct a particular Defect is a fundamental breach of Contract and the Contractor fails to correct it within a reasonable period of time determined by the Engineer;
- d) The Contractor does not maintain a Security, which is required;
- e) The Contractor has delayed the completion of the Works by the number of days for which the maximum amount of liquidated damages can be paid, as defined in relevant clause.
- f) The Contractor fails to provide insurance cover as required under relevant clause.
- g) If the Contractor, in the judgment of the Employer, has engaged in the corrupt or fraudulent practices as defined in GCC in competing for or in executing the Contract.
- h) If the Contractor fails to set up a field laboratory with the prescribed equipment, within the period specified in the Contract Data; and
- i) Any other fundamental breaches as specified in the Contract Data.
- j) If the Contractor fails to deploy machinery and equipment or personnel as specified in the Contract Data at the appropriate time.

46.3 When either party to the contract gives notice of a breach of contract to the Engineer for a cause other than those listed above, the Engineer shall decide whether the breach is fundamental or not.

46.4 Notwithstanding the above, the Employer may terminate the Contract for convenience.

46.5 If the Contract is terminated, the Contractor shall stop work immediately, make the Site safe and secure, and leave the Site as soon as reasonably possible.

47. Payment upon Termination

47.1 If the Contract is terminated because of a fundamental breach of Contract by the Contractor, the Engineer shall issue a certificate for value of the work done and materials ordered less liquidated damages, if any, less advance payments received up to the date of the issue of the certificate and less the percentage to apply to the value of the work not completed, as indicated in the Contract Data. If the total amount due to the Employer exceeds any payment due to the Contractor, the difference shall be recovered from the security deposit, and performance security. If any amount is still left un-recovered it will be a debt due from the Contractor to the Employer.

47.2 If the Contract is terminated at the Employer's convenience, the Engineer shall issue a certificate for the value of the work done, the reasonable cost of removal of Equipment, repatriation of the Contractor's personnel employed solely on the Works, and the Contractor's costs of protecting and securing the Works and less advance payments received up to the date of the certificate, less other recoveries due in terms of the Contract, and less taxes due to be deducted at source as per applicable law.

48. Property

48.1 All Materials on the Site, Plant, Equipment, Temporary Works, and Works shall be deemed to be the property of the Employer for use for completing balance construction work if the Contract is terminated because of the Contractor's default, till the Works is completed after which it will be transferred to the Contractor and credit, if any, given for its use.

49. Release from Performance

If the Contract is frustrated by the outbreak of war or by any other event entirely outside the control of the Employer or the Contractor, the Engineer shall certify that the Contract has been frustrated. The Contractor shall make the Site safe and stop work as quickly as possible after receiving this certificate and shall be paid for all work carried out before receiving it and for any work carried out afterwards to which a commitment was made.

F. Other Conditions of Contract

50. Labour

50.1 The Contractor shall, unless otherwise provided in the Contract, make his own arrangements for the engagement of all staff and labour, local or other, and for their payment, housing, feeding and transport.

50.2 The Contractor shall, if required by the Engineer, deliver to the Engineer a return in detail, in such form and at such intervals as the Engineer may prescribe, showing the staff and the number of the several classes of labour from time to time employed by the Contractor on the Site and such other information as the Engineer may require.

51. Compliance with Labour Regulations

- a) During continuance of the Contract, the Contractor and his sub-Contractors shall abide at all times by all existing labour enactments and rules made there under, regulations, notifications and bye laws of the State or Central Government or local authority and any other labour law (including rules), regulations, bye laws that may be passed or notification that may be issued under any labour law in future either by the State or the Central Government or the local authority.
- b) Furthermore, the Contractor shall keep the Employer indemnified in case any action is taken against the Employer by the competent authority on account of contravention of any of the provisions of any Act or rules made there under, regulations or notifications including amendments. If the Employer is caused to pay or reimburse, such amounts as may be necessary to cause or observe, or for non-observance of the provisions stipulated in the notifications/bye laws/Acts/Rules/regulations including amendments, if any, on the part of the Contractor, the Engineer/Employer shall have the right to deduct any money due to the Contractor including his amount of performance guarantee. The Employer/Engineer shall also have right to recover from the Contractor any sum required or estimated to be required for making good the loss or damage suffered by the Employer.
- c) The Contractor shall require his employees to obey all applicable laws, including those concerning safety at work.
- d) The employees of the Contractor and the Sub-Contractor in no case shall be treated as the employees of the Employer at any point of time.

52. Drawings and Photographs of the Works

52.1 The Contractor shall do photography/video photography of the site firstly before the start of the work, secondly mid-way in the execution of different stages of work as required by Engineer In-charge and lastly after the completion of the work. No separate payment will be made to the Contractor for this.

52.2 The Contractor shall not disclose details of Drawings furnished to him and works on which he is engaged without the prior approval of the Engineer in writing. No photograph of the works or any part thereof or plant employed thereon, except those permitted under above clause, shall be taken or permitted by the Contractor to be taken by any of his employees or any employees of his sub-Contractors without the prior approval of the Engineer in writing. No photographs/ Video photography shall be published or otherwise circulated without the approval of the Engineer in writing.

53. The Apprentices Act, 1961

The Contractor shall duly comply with the provisions of the Apprentices Act 1961 (III of 1961), the rules made there under and the orders that may be issued from time to time under the said Act and the said Rules and on his failure or neglect to do so, he shall be subject to all liabilities and penalties provided by the said Act and said Rules.

54. Contract Document

The documents forming the contract are to be taken as mutually explanatory of one another. Unless otherwise provided in the contract, the priority of the documents forming the contract shall be, as follows:

- 1) Contract Agreement (if completed)
- 2) The letter of Acceptance
- 3) The Bid:
- 4) Addendum to Bid; if any
- 5) Tender Document
- 6) The Bill of Quantities:
- 7) The Specification:
- 8) Detailed Engineering Drawings
- 9) Standard General Conditions of Contracts (GCC)
- 10) All correspondence documents between bidder/contractor and MCGM.

55. Conflict of Interest

The Applicant shall not have a conflict of interest (the “Conflict of Interest”) that affects the Bidding Process. Any Applicant found to have a Conflict of Interest shall be disqualified. An Applicant shall be deemed to have a Conflict of Interest affecting the Bidding Process, if

- 1) A constituent of such Applicant is also a constituent of another Applicant; or
- 2) Such Applicant has the same legal representative for purposes of this Application as any other Applicant; or
- 3) Such Applicant, or any Associate thereof has a relationship with another Applicant, or any Associate thereof, directly or through common third party/ parties, that puts either or both of them in a position to have access to each other’s information about, or to influence the Application of either or each other; or
- 4) The Applicant shall be liable for disqualification if any legal, financial or technical adviser of the Authority in relation to the Project is engaged by the Applicant, its Member or any Associate thereof, as the case may be, in any manner for matters related to or incidental to the Project. For the avoidance of doubt, this disqualification shall not apply where such adviser was engaged by the Applicant, its Member or Associate in the past but its assignment expired or was terminated 6 (six) months prior to the date of issue of this TENDER. Nor will this disqualification apply where such adviser is engaged after a period of 3 (three) years from the date of commercial operation of the Project.

56. Applications and costs thereof

No Applicant shall submit more than one Application for the Project. An applicant applying individually shall not be entitled to submit another application either individually. The Applicant shall be responsible for all of the costs associated with the preparation of their Applications and their

participation in the Bid Process. The Authority will not be responsible or in any way liable for such costs, regardless of the conduct or outcome of the Bidding Process.

57. Acknowledgment by Applicant

It shall be deemed that by submitting the Application, the Applicant has:

- a. made a complete and careful examination of the tender;
- b. received all relevant information requested from the Authority;
- c. accepted the risk of inadequacy, error or mistake in the information provided in the tender or furnished by or on behalf of the Authority relating to any of the matters referred; and
- d. Agreed to be bound by the undertakings provided by it under and in terms hereof
“The Authority” shall not be liable for any omission, mistake or error in respect of any of the above or on account of any matter or thing arising out of or concerning or relating to the TENDER or the Bidding Process, including any error or mistake therein or in any information or data given by the Authority.

58. Right to accept or reject any or all Applications/ Bids

Notwithstanding anything contained in this TENDER, “The Authority” reserves the right to accept or reject any Application and to annul the Bidding Process and reject all Applications/ Bids, at any time without any liability or any obligation for such acceptance, rejection or annulment, and without assigning any reasons therefore. In the event that the Authority rejects or annuls all the Bids, it may, in its discretion, invite all eligible Bidders to submit fresh Bids hereunder.

“The Authority” reserves the right to reject any Application and/ or Bid if:

- (a) at any time, a material misrepresentation is made or uncovered, or
- (b) the Applicant does not provide, within the time specified by the Authority, the supplemental information sought by the Authority for evaluation of the Application.

In case it is found during the evaluation or at any time before signing of the Agreement or after its execution and during the period of subsistence thereof including the concession thereby granted by “The Authority”, that one or more of the pre-qualification conditions have not been met by the Applicant, or the Applicant has made material misrepresentation or has given any materially incorrect or false information, the Applicant shall be disqualified forthwith if not yet appointed as the Successful Bidder either by issue of the LOA (Letter of Approval) or entering into of the Agreement, and if the Applicant has already been issued the LOA or has entered into the Concession Agreement, as the case may be, the same shall, notwithstanding anything to the contrary contained therein or in this TENDER, be liable to be terminated, by a communication in writing by “The Authority” to the Applicant, without the Authority being liable in any manner whatsoever to the Applicant and without prejudice to any other right or remedy which the Authority may have under this TENDER, the Bidding Documents, the Concession Agreement or under applicable law. “The Authority” reserves the right to verify all statements, information and documents submitted by the Applicant in response to the TENDER. Any such verification or lack of such verification by the Authority shall not relieve the Applicant of its obligations or liabilities hereunder nor will it affect any rights of the Authority

there under.

59. The bid shall be rejected if the bidder-

- a) Stipulates the validity period less than 180 days.
- b) Stipulates own condition/conditions.
- c) Does not fill and (digital) sign undertaking forms, which are incorporated, in the document.

60. Clarifications

Applicants requiring any clarification on the tender may notify “the Authority” in writing or by fax or e-mail. They should send in their queries before the date specified in the header data. “The Authority” shall Endeavor to respond to the queries within the period specified therein. The responses will be sent by fax and/or e-mail. The Authority will forward all the queries and its responses thereto, to all purchasers of the TENDER without identifying the source of queries.

“The Authority” shall Endeavor to respond to the questions raised or clarifications sought by the Applicants. However, the Authority reserves the right not to respond to any question or provide any clarification, in its sole discretion, and nothing in this Clause shall be taken or read as compelling or requiring the Authority to respond to any question or to provide any clarification, but not later than the date provided in header data.

“The Authority” may also on its own motion, if deemed necessary, issue interpretations and clarifications to all Applicants. All clarifications and interpretations issued by the Authority shall be deemed to be part of the tender. Verbal clarifications and information given by Authority or its employees or representatives shall not in any way or manner be binding on the Authority.

61. Amendment of tender

At any time prior to the deadline for submission of Application, the Authority may, for any reason, whether at its own initiative or in response to clarifications requested by an Applicant, modify the tender by the issuance of Addendum.

Any Addendum thus issued will be sent in writing/ Fax/ Email to all those who have purchased the tender.

In order to afford the Applicants a reasonable time for taking an Addendum into account, or for any other reason, the Authority may, in its sole discretion, extend the Application Due Date.

Preparation and Submission of Application

62. Language

The Application and all related correspondence and documents in relation to the Bidding Process shall be in English language. Supporting documents and printed literature furnished by the Applicant with the Application may be in any other language provided that they are accompanied by translations of all the pertinent passages in the English language, duly authenticated and certified by the Applicant. Supporting materials, which are not translated into English, may not be considered. For the purpose of interpretation and evaluation of the Application, the English language translation shall prevail.

63. Format and signing of Application

The Applicant shall provide all the information sought under this TENDER. The Authority will evaluate only those Applications that are received in the required formats and complete in all respects. Incomplete and /or conditional Applications shall be liable to rejection.

The Applicant will upload bid in One Folder in electronic form which shall contain the scanned certified copies of the documents given below and the documents uploaded has to be digitally signed by the bidder. These copies shall be certified by Practicing Notary approved by the Govt. of Maharashtra or Govt. of India with his stamp, clearly stating his name & registration number, except where original documents are demanded.

64. Marking of Applications

The Applicant shall submit the Application in the format specified at Appendix-I, together with the documents, upload in folder as “VENDOR” together with their respective enclosures Applications submitted by fax, telex, telegram shall not be entertained and shall be rejected outright.

65. Late Applications

Applications received by the Authority after the specified time on the Application Due Date shall not be eligible for consideration and shall be summarily rejected.

66. Confidentiality

Information relating to the examination, clarification, evaluation, and recommendation for the short-listed qualified Applicants shall not be disclosed to any person who is not officially concerned with the process or is not a retained professional advisor advising the Authority in relation to or matters arising out of, or concerning the Bidding Process. The Authority will treat all information, submitted as part of Application, in confidence and will require all those who have access to such material to treat the same in confidence. The Authority may not divulge any such information unless it is directed to do so by any statutory entity that has the power under law to require its disclosure or is to enforce or assert any right or privilege of the statutory entity and/ or the Authority or as may be required by law or in connection with any legal process.

67. Clarification Of Financial Bids

To assist in the examination, evaluation and comparison of Bids, the Engineer may, at his discretion, ask any bidder for clarification of his Bid, including breakdown of unit rates. The request for clarification and the response shall be in writing or by post/facsimile/e- mail. No Bidder shall contact the Engineer on any matter relating to his bid from the time of the bid opening to the time the contract is awarded. Any effort by the Bidder to influence the Engineer in the Engineer's bid evaluation, bid comparison or contract award decisions may result in the rejection of the Bidder's bid.

68. Inspection of site and sufficiency of tender:

- 1) The Contractor shall inspect and examine the site and its surrounding and shall satisfy himself before submitting his tender as to the nature of the ground and subsoil (so far as is practicable), the form and nature of the site, the quantities and nature of the work and materials necessary for the completion of the works and means of access to the site, the accommodation he may require and in general shall himself obtain all necessary information as to risk, contingencies and other circumstances which may influence or affect his tender. He shall also take into consideration the hydrological and climatic conditions.
- 2) The Employer may make available to the Contractor data on hydrological and sub- surface conditions as obtained by or on his behalf from investigations relevant to the works but the Contractor shall be responsible for his own interpretation thereof. The contractor shall engage his investigating agency with prior approval of the Engineer from the approved list of such agencies by MCGM or Govt at his cost initially before commencing actual work and which shall be reimbursed immediately subject to satisfaction of the Engineer for faithful compliance and submission of required data regarding such investigation within specified time.
- 3) The Contractor shall be deemed to have satisfied himself before tendering as to the correctness and sufficiency of his tender for the works and of the rates and prices quoted in the schedule of works / items / quantities, or in Bill of Quantities, which rates and prices shall, except as otherwise provided cover all his obligations under the Contract and all matters and things necessary for proper completion and maintenance of the works. No extra charges consequent on any misunderstanding.
- 4) **Not Foreseeable Physical Obstructions or Conditions:** If, however, during the execution of the Works the Contractor encounters physical obstructions or physical conditions, other than climatic conditions on the Site, which obstructions or conditions were, in his opinion, not foreseeable by an experienced contractor, the Contractor shall forthwith give notice thereof to the Engineer. On receipt of such notice, the Engineer shall, if in his opinion such obstructions or conditions could not have been reasonably foreseen by an experienced contractor, after due consultation with the Contractor, determine:
 - any extension of time to which the Contractor is entitled and
 - The amount of any costs which may have been incurred by the Contractor by reason of such obstructions or conditions having been encountered, which shall be added to

the Contract Price.

- and shall notify the Contractor accordingly. Such determination shall take account of any instruction which the Engineer may issue to the Contractor in connection therewith, and any proper and reasonable measures acceptable to the Engineer which the Contractor may take in the absence of specific instructions from the Engineer. However such costing shall be got approved by the competent authority as governed vide rules prevailing with authority.

5) Office for the Engineer (Works costing upto Rs.50 Lakhs)

The Contractor shall at his own cost and to satisfaction of the Engineer provide a small temporary office, at the work-site which will include tables, chairs and lockers for keeping the records. He shall also make necessary arrangements for drinking water, telephone with a pre-requisite of e-governance and electronic communication. These offices are not to be allowed on public roads without the written instruction of the Engineer. These offices should be preferably located within 50 to 500 m of the worksite. In case the office is more than 500m away from the worksite, the contractor is to provide conveyance for Municipal Staff.

6) Office for the Engineer (Works costing above Rs.50 lakhs)

The Contractor shall at his own cost and to satisfaction of the Engineer provide a temporary office at the work-site which will include tables, chairs and lockers for keeping the records. He shall also make necessary arrangements for drinking water, latrines, with doors, windows, locks, bolts and fastenings sufficient for security for the Engineer, and his subordinates, as close to the works from time to time in progress as can be conveniently arranged, and shall at his own cost furnish the office with such chairs, tables, lockers, locks and fastenings as may be required by the Engineer, and no expense of any kind in connection with the erection or upkeep of the offices or fittings shall be borne by the Corporation, but all such work shall be carried out by the Contractor and the expenses thereof defrayed by him. The Contractor shall also make water connections and fit up stand pipe with a bib tap at each office. The latrines and the water connections shall be subject to all the conditions herein elsewhere laid down for temporary water connection and latrines generally with all requisite equipments for e-governance and electronic and digital communication. These offices are not to be allowed on public roads without the written instruction of the Engineer. These offices should be preferably located within 50 to 500 m of the worksite. In case the office is more than 500m away from the worksite, the contractor is to provide conveyance. Also, for staff working beyond working hours the contractor has to provide conveyance.

7) Permission for provision and removal of office on completion of work:

The tenderer shall obtain permission for provision of site office, cement go-down, store, etc. on payment of necessary cost implication. The cement go-down, Watchman cabins, etc. shall be provided as directed and shall be removed by the Tenderers on completion of the work at their cost. It is binding on the Tenderer to fulfill requirements of Environmental Authorities. The location of such office shall be finalized and got approved from the Engineer before erection/commencement work.

8) Contractor's office near works:

The Contractor shall have an office near the works at which notice from the Commissioner or the Engineer may be served and shall, between the hours of sunrise and sunset on all working days, have a clerk or some other authorized person always present at such office upon whom such notices may be served and service of any notices left with such clerk or other authorized person or at such office shall be deemed good service upon the Contractor and such offices shall have pre-requisite facilities for e- governance.

69. Official Secrecy:

The Contractor shall of all the persons employed in any works in connection with the contract that the India Official Secrets Act 1923 (XIX of 1923) applies to them and will continue to apply even after execution of the said works and they will not disclose any information regarding this contract to any third party. The contractor shall also bring into notice that, any information found to be leaked out or disclosed the concern person as well as the Contractor will be liable for penal action; further the Corporation will be at liberty to terminate the contract without notice.

70. Subsequent Legislation:

If on the day of submission of bids for the contract, there occur changes to any National or State stature, Ordinance, decree or other law or any regulation or By-laws or any local or other duly constituted authority or the introduction of any such National or State Statute, Ordinance, decree or by which causes additional or reduced cost to the Contractor, such additional or reduced cost shall, after due consultation with the Contractor, be determined by the concerned Engineering Department of MCGM and shall be added to or deducted from the Contract Price with prior approval of competent authority and the concerned Engineering Department shall notify the Contractor accordingly with a copy to the Employer. MCGM reserve the right to take decision in respect of addition/reduction of cost in contract.

71. Patent, Right and Royalties:

The contractor shall save harmless and indemnify the Corporation from and against all claims and proceedings for or on account of infringement of any Patent rights, design trademark or name of other protected rights in respect of any constructional plant, machine work, or material used for or in connection with the Works or any of them and from and against all claims, proceedings, damages, costs, charges and expenses whatsoever in respect thereof or in relation thereto. Except where otherwise specified, the contractor shall pay all tonnage and other royalties, rent and other payments or compensation, if any, for getting stone, sand, gravel, clay or other materials required for the works or any of them.

72. Payments, Tax and Claims:

- **The limit for unforeseen claims**

Under no circumstances whatever the contractor shall be entitled to any compensation from MCGM on any account unless the contractor shall have submitted a claim in writing to the Eng-in-

change within 1 month of the case of such claim occurring.

- **No interest for delayed payments due to disputes, etc:**

It is agreed that the Municipal Corporation of Greater Mumbai or its Engineer or Officer shall not be liable to pay any interest or damage with respect of any moneys or balance which may be in its or its Engineer's or officer's hands owing to any dispute or difference or claim or misunderstanding between the Municipal Corporation of Greater Bombay or its Engineer or Officer on the one hand and the contractor on the other, or with respect to any delay on the part of the Municipal Corporation of Greater Bombay or its Engineer or Officers in making periodical or final payments or in any other respect whatever.

73. Settlement of Disputes:

- **Termination of contract for death**

If the Contractor is an individual or a proprietary concern and the individual or the proprietor dies and if the Contractor is a partnership concern and one of the legal representative of the individual Contractor or the proprietor of the proprietary concern and in case of partnership, the surviving partners, are capable of carrying out and completing the contract, the Commissioner shall be entitled to cancel the contract as to its uncompleted part without the Corporation being in any way liable to payment of any compensation to the estate of the deceased Contractor and or to the surviving partners of the Contractor's firm on account of the cancellation of the contract. The decision of the Commissioner that the legal representative of the deceased Contractor or surviving partners of the Contractor's firm cannot carry out and complete the contract shall be final and binding on the parties. In the event of such cancellation the Commissioner shall not hold estate of the deceased Contractor and or surviving partners of the Contractor's firm liable in damages for not completing the contract.

- **Settlement of Disputes:**

If any dispute or differences of any kind whatsoever other than those in respect of which, the decision of any person is, by the Contract, expressed to be final and binding) shall arise between the Employer and the Contractor or the Engineer and the Contractor in connection with or arising out of the Contract or carrying out of the Works (Whether during the progress of the Works or after their completion and whether before or after the termination, abandonment or breach of the Contract) it, the aggrieved party may refer such dispute within a period of 7 days to the concerned Addl. Municipal Commissioner who shall constitute a committee comprising of three officers i.e. concerned Deputy Municipal Commissioner or Director (ES&P), Chief Engineer other than the Engineer of the Contract and concerned Chief Accountant. The Committee shall give decision in writing within 60 days. Appeal on the Order of the Committee may be referred to the Municipal Commissioner within 7 days. Thereafter the Municipal Commissioner shall constitute a Committee comprising of three Addl. Municipal Commissioners including Addl. Municipal Commissioner in charge of Finance Department. The Municipal Commissioner within a period of 90 days after being requested to do so shall give written notice of committee's decision to the Contractor. Save as herein provided such decision in respect of every matter so referred shall be

final and binding upon both parties until the completion of the works, and shall forthwith be given effect to by the Contractor who shall proceed with the works with due diligence, whether he requires arbitration as hereinafter provided or not. If the Commissioner has given written notice of the decision to the Contractor and no Claim to arbitration has been communicated within a period of 90 days from receipt of such notice the said decision shall remain final and binding upon the Contractor.

74. Arbitration and Jurisdiction:

If the Commissioner shall fail to give notice of the decision as aforesaid within a period of 90 days after being requested as aforesaid, or if the Contractor be dissatisfied with any such decision, then the Contractor may within 90 days after receiving notice of such decision or within 90 days after the expirations of the first named period of 90 days (as the case may be) require that the matter or matters in dispute be referred to arbitration as hereinafter provided.

(i) In case of contract where the contract price and/or contract value is less than Rs. 5,00,00,000/- [Rupees Five Crore Only], any dispute arising out of or in connection with this contract, including any question regarding its existence, validity or termination, shall be referred to a mutually agreed arbitral tribunal in accordance with the Arbitration and Conciliation Act 1996 [amended upto date]. The arbitral tribunal shall consist of a sole arbitrator, as mutually agreed upon by the parties and the said dispute shall be finally resolved by the said arbitral tribunal. The decision of the arbitral tribunal shall be in writing [with reasons] and which will be final and binding upon the parties hereto and the expenses of arbitration shall be paid as may be determined by the arbitral tribunal. The seat of arbitration shall be Mumbai. The venue of arbitration shall be within the limits of Brihan Mumbai. The language of the arbitration shall be English.

If the parties fails to appoint mutually agreed arbitral tribunal, within the period of 30 days from the date of application seeking arbitration in the dispute, the arbitral tribunal shall be appointed bt the recognized arbitral institution i.e. Mumbai Centre for International Arbitration [approved by Government of Maharashtra under G.R. No. ARB/Case No.1,/2017/D-19 dtd.28.02.2017] as per the Arbitration Rules of Mumbai centre for International Arbitration then in force [‘MCIA Rules’]

(ii) In case of contract where the contract price and/ or contract value is Rs 5,00,00,000/- [Rupees Five Crore Only] or more, any dispute arising out of or in connection with such a contract, including any question regarding its existence, validity or termination , shall be directly referred to and finally resolved by the recognized arbitral institution i.e. Mumbai Centre for International Arbitration [approved by Government of Maharashtra under G.R. No. ARB/Case No.1,/2017/D-19 dtd.28.02.2017] as per the Arbitration Rules of the Mumbai centre for International Arbitration then in force [‘MCIA Rules’]. The arbitral tribunal shall consist of a sole arbitrator. The seat of the arbitration shall be Mumbai. The language of the arbitration shall be English.

75. Copyright:

The copyright of all drawings and other documents provided by the Contractor under the contract shall remain vested in the Contractor or his sub-contractors as the case may be the employer shall have a license to use such drawings and other documents in connection with the design, construction, operation, maintenance of the works. At any time the Employer shall have further license without additional payment to the Contractor to use any such drawings or documents for the purpose of

making any improvement of the works or enlargement or duplication of any part thereof, provided that such improvement, enlargement, or duplication by itself or in conjunction with any other improvements, enlargements or duplications already made in accordance with the further license does not result in the duplication of the whole works.

76. Receipts to be signed in firm's name by any one of the partners:

Every receipt for money which may become payable or for any security which may become transferable to the Contractor under these present shall, if signed in the partnership name by any one of the partners, be a good and sufficient discharge to the Commissioner and Municipal Corporation in respect of the money or security purporting to be acknowledged thereby, and in the event of death of any of the partners during the pendency of this contract, it is hereby expressly agreed that every receipt by any one of the surviving partners shall, if so signed as aforesaid, be good and sufficient discharge as aforesaid provided that nothing in this clause contained shall be deemed to prejudice or effect any claim which the Commissioner or the Corporation may hereafter have against the legal representatives of any partners so dying or in respect of any breach of any of the conditions thereof, provided also that nothing in this clause contained shall be deemed prejudicial or affect the respective rights or obligations of the Contractors and of the legal representatives of any deceased Contractors interest.

77. Proprietary data

All documents and other information supplied by the Authority or submitted by an Applicant to the Authority shall remain or become the property of the Authority. Applicants are to treat all information as strictly confidential and shall not use it for any purpose other than for preparation and submission of their Application. The Authority will not return any Application or any information provided along therewith.

78. Correspondence with the Applicant

Save and except as provided in this TENDER, the Authority shall not entertain any correspondence with any Applicant in relation to the acceptance or rejection of any Application.

79. Price Variation Clause

The Contractor shall be reimbursed or shall refund to the Corporation as he case may be the variation in the value of the work carried out from time to time, depending on whether the prices of material and labour as a whole rise or fall, and the method adopted for such computations shall be as given below, it being clearly understood that the contractor shall have no claim for being reimbursed on the ground that the price of a particular material or group of materials have risen beyond the limits of the presumptions made in the following paras, however, no price variations shall be made applicable for contracts upto 12 months:

- (A) Controlled materials: Price variations shall be permitted in respect of these materials the price level of which is controlled by the Government or its agency. The rate ruling on the date of submission of the tender shall be considered as the basic price of such material for adjustment. Any variation in this rate shall be considered for reimbursement to the contractor

or refund to be claimed from the contractor as the case may be. The contractor shall, for the purpose of adjustment submit in original the relevant documents from the suppliers.

(B) Labour and other materials: For the purpose of this contract and for allowing reimbursement of refund on account of variation of prices of (i) labour, and (ii) materials other than materials mentioned in A above, computation will be based on the formula enunciated below which is based on the presumptions that:

- i) The general price level of labour, rises or falls in proportion to the rise or fall of consumer price index number 9 (general) for working class in Mumbai.
- ii) The general price level of materials rises or falls in proportion to rise or fall of whole-sale price index as published by 'Economic Adviser to Govt. of India'.
- iii) And that the component of labour is to the extent of 30 percent of 88 percent and the component of materials is to the extent of 70 percent of 88 percent of the value of the work carried out. The remaining 12 percent being the presumptive profit of the contractor.

a) Formula for Labour component:

$$VL = \frac{(0.88 R) \times 30}{100} \times \frac{(I - IO)}{IO}$$

b) Formula for Material component:

$$VM = \frac{(0.88 R \times 70 - C)}{100} \times \frac{(W - WO)}{WO}$$

Where –

VL = Amount of price variation to be reimbursed or claimed as refund on account of general rise or fall of index referred to above.

I = Consumer Price Index number of working class for Mumbai (declared by the Commissioner of Labour and Director of Employment, Mumbai) applicable to the period under reference (base year ending 2004-05 as 100 i.e. new series of indices).

IO = Consumer price index number for working class for Mumbai (declared by the Commissioner of labour and Director of Employment, Mumbai) prevailing, on the day of 28 days prior to the date of submission of the tender.

VM = The amount of price variation to be reimbursed or claimed as refund on account of general rise or fall of wholesale price index for period under reference.

W = Average wholesale price index as published by Economic Adviser to Govt. of India applicable to the period under reference.

WO = Wholesale price index as stated above prevailing on the day of 28 days prior to the date of submission of the tender.

R = Total value of the work done during the period under reference as recorded in the Measurement Book excluding water charges and sewerage charges but including cost of excess in respect of item upto 50 percent

C = Total value of Controlled materials used for the works as recorded in Measurement Book and paid for at original basic rate plus the value of materials used .

- i) The quantity of the Controlled material adopted in working out the value of 'C' shall be inclusive of permitted wastages as / if mentioned in specifications.
- ii) The basic rate for the supply of controlled material shall be inclusive of all the components of cost of materials excluding transport charges incurred for bringing the material from place of delivery to the site.

Computations based on the above formula will be made for the period of each bill separately and reimbursement will be made to (when the result is plus) and refund will be claimed from (when the result is minus) the contractor's next bill. The above formulae will be replaced by the formulae in Annexure-I as and when mentioned in special conditions of contract

The operative period of the contract for application of price variation shall mean the period commencing from the date of commencement of work mentioned in the work order and ending on the date when time allowed for the work order and ending on the date when time allowed for the work specified in the contract for work expires, taking into consideration, the extension of time, if any, for completion of the work granted by Engineer under the relevant clause of the conditions of contract in cases other than those where such extension is necessitated on account of default of the contractor.

The decision of the Engineer as regards the operative period of the contract shall be final and binding on the contractors.

- iii) Where there is no supply of controlled items to contractor the component 'C' shall be taken as zero.

(C) Adjustment after completion: If the Contractor fails to complete the works within the time for completion adjustment of prices thereafter until the date of completion of the works shall be made using either the indices or prices relating to the prescribed time for completion, or the current indices or prices whichever is more favorable to the employer, provided that if an extension of time is granted, the above provision shall apply only to adjustments made after the expiry of such extension of time.

(D) Price variation will be calculated similarly and separately for extra items and / or excess quantities and provisional sums calculated under Sub Clause 10 (b)A (i)&(ii) and Sub Clause 10 (b) B(ii) based on the above formula/formulae in Annexure-I as and when mentioned in Special conditions of contract; IO and WO being the indices applicable to the date on which the rates under Sub Clause 10 (a)A (i)&(ii) and Sub Clause 10 (a) B(iii) are fixed. No price variation shall be admissible for FAIR items created during execution.

80. Maximum Price Variation shall be as follows:

Time period of Project	Maximum limit of Price Variation
Upto 12 Months	No Variation allowed
Above 12 Months to 24 Months	5%
Above 24 Months	10%

- **Approval of AMC/MC shall be obtained before invitation of tender in case of any changes in above.**

Note:

- 1) **The extension in time period for the projects originally estimated including monsoon results in change of price variation slabs as mentioned above i.e. From first slab to second slab or from second slab to third slab, then the maximum limit of original slab will prevail.**
- 2) Operative period shall mean original or extended time period of contract.

For example:

Extension of Time period	Maximum limit of Price Variation
If original period of 11 Months including monsoon extends to 16. The operative period will be 11+5 Months	Not allowed
If original period of 11 Months excluding monsoon extends to 16. The operative period will be 11+5 Months	5%

Price Variation during Extended Period of Contract:

i. Extension Due To Modification & Extension for delay due to MCGM :

The price variation for the period of extension granted shall be limited to the amount payable as per the Indices. In case the indices increases or decreases, above/below the indices applicable, to the last month of the original or extended period vide clause 8(1)(a)(i) and (ii) of standard GCC

ii. Extension Of Time For Delay Due To Contractor :

- a) The price variation for the period of extension granted shall be limited to the amount payable as per the Indices in case the indices increase, above the indices applicable, to the last month of the original completion period or the extended period vide above clause 8(1)(a)(i) and (ii) of standard GCC.
- b) The price variation shall be limited to the amount payable as per the indices, in case the indices decrease or fall below the indices applicable, to the last month of original / extended period of completion period vide above clause 8(1)(b) of standard GCC, then lower indices shall be adopted.

- iii. Extension of Time For Delay due to reasons not attributable to MCGM and Contractor (Reference Cl.8(d) of Standard GCC):

The price variation for the period of extension granted shall be limited to the amount payable as per the Indices in case the indices increases or decreases, above/below the indices applicable, to the last month of the original period.

81. Payment:

Interim Payment :

- (i) Interim bills shall be submitted by the Contractor from time to time (but at an interval of not less than one month) for the works executed. The Engineer shall arrange to have the bills verified by taking or causing to be taken, where necessary, the requisite measurement of work.
- (ii) Payment on account for amount admissible shall be made on the Engineer certifying the sum to which the Contractor is considered entitled by way of interim payment for all the work executed, after deducting there from the amount already paid, the security deposit / retention money and such other amounts as may be deductible or recoverable in terms of the contract.
- (iii) On request, the contractor will be paid upto 75 percent of the value of the work carried out as an adhoc payment in the first week of next month after deducting there from recoveries on account of advances, interest, retention money, income tax etc. The balance payment due will be paid thereafter.
- (iv) No interim payment will be admitted until such time the Contractor have fully complied with the requirement of the Condition no.8 (g) and 8 (h) concerning submission and approval of Network Schedule for the works, as detailed in Condition 8 (h). A fixed sum shall be held in abeyance at the time of next interim payment for non-attainment of each milestone in the network and shall be released only on attainment of the said milestone.
- (v) An interim certificate given relating to work done or material delivered may be modified or corrected by a subsequent interim certificate or by the final certificate. No certificate of the Engineer supporting an interim payment shall of itself be conclusive evidence that any work or materials to which it relates is / are in accordance with the contract.

82. Banning/De-Registration of Agencies of Construction works in MCGM

- **The regulations regarding Demotion/ Suspension Banning for specific period or permanently / De-Registration shall be governed as per the respective condition in Contractor Registration Rules of MCGM.**

83. JOINT VENTURE (Not applicable to this tender)

~~In case if Joint Venture is allowed for the Project, the guidelines for JV as follows shall be incorporated in the Tender Document:~~

- ~~a) Joint Venture should be allowed only when the number of identifiable different works is more than one and/or the estimated cost of tender is more than Rs.100 Crores. JV shall also be~~

allowed for complex technical work below Rs.100 Crores with the approval of concerned AMC

- b) ~~Separate identity/name shall be given to the Joint Venture firm.~~
- e) ~~Number of members in a JV firm shall not be more than three in normal circumstances, if the work involves only one discipline (say Civil or Electrical). If number of members in JV is required to be more than three, then approval of concerned AMC needs to be sought.~~
- d) ~~A member of JV firm shall not be permitted to participate either in individual capacity or as a member of another JV firm in the same tender.~~
- e) ~~The tender form shall be purchased and submitted in the 'name of the JV firm or any constituent member of the JV.~~
- f) ~~Normally EMD shall be submitted only in the name of the JV and not in the name of constituent member. However, EMD in the name of lead partner can be accepted subject to submission of specific request letter from lead partner stating the reasons for not submitting the EMD in the name of JV and giving written confirmation from the JV partners to the effect that the EMD submitted by the lead partner may be deemed as EMD submitted by JV firm.~~
- g) ~~One of the members of the JV firm shall be the lead member of the JV firm who shall have a majority (at least 51%) share of interest in the JV firm. The other members shall have a share of not less than 20% each in case of JV firms with up to three members and not less than 10% each in case of JV firms with more than three members. In case of JV firm with foreign member(s), the lead member has to be an Indian firm with a minimum share of 51%.~~
- h) ~~A copy of Letter of Intent or Memorandum of Understanding (MoU) executed by the JV members shall be submitted by the JV firm along with the tender. The complete details of the members of the JV firm, their share and responsibility in the JV firm etc. particularly with reference to financial technical and other obligation shall be furnished in the agreement.~~
- i) ~~Once the tender is submitted, the agreement shall not be modified/altered/terminated during the validity of the tender. In case the tenderer fails to observe/comply with this stipulation, the full Earnest Money Deposit (EMD) shall be forfeited. In case of successful tenderer, the validity of this agreement shall be extended till the currency of the contract expires.~~
- j) ~~Approval for change of constitution of JV firm shall be at the sole discretion of the MCGM. The constitution of the JV firm shall not be allowed to be modified after submission of the tender bid by the JV firm except when modification becomes inevitable due to succession laws etc. and in any case the minimum eligibility criteria should not get vitiated. In any case the Lead Member should continue to be the Lead Member of the JV firm. Failure to observe this requirement would render the offer invalid.~~
- k) ~~Similarly, after the contract is awarded, the constitution of JV firm shall not be allowed to be altered during the currency of contract except when modification become inevitable due to succession laws etc. and in any case the minimum eligibility criteria should not get vitiated. Failure to observe this stipulation shall be deemed to be breach of contract with all consequential penal action as per contract condition.~~

- ~~l) On award of contract to a JV firm, a single Performance Guarantee shall be required to be submitted by the JV firm as per tender conditions. All the Guarantees like Performance Guarantee, Bank Guarantee for Mobilization advance, machinery Advance etc. shall be accepted only in the name of the JV firm and no splitting of guarantees amongst the members of the JV firm shall be permitted.~~
- ~~m) On issue of LOA, an agreement among the members of the JV firm (to whom the work has been awarded) has to be executed and got registered before the Registrar of the Companies under Companies Act or before the Registrar / Sub Registrar under the Registration Act, 1908. This agreement shall be submitted by the JV firm to the MCGM before signing the contract agreement for the work. (This agreement format should invariably be part of the tender condition). In case the tenderer fails to observe/comply with this stipulation, the full Earnest Money Deposit (EMD) shall be forfeited and other penal actions due shall be taken against partners of the JV and the JV. This joint venture agreement shall have, inter alia, following clauses:-~~
- ~~(i) **Joint and several liability** — The members of the JV firm to which the contract is awarded, shall be jointly and severally liable to the Employer (MCGM) for execution of the project in accordance with General and Special conditions of the contract. The JV members shall also be liable jointly and severally for the loss, damages caused to the MCGM during the course of execution of the contract or due to no execution of the contract or part there of.~~
 - ~~(ii) **Duration of the Joint Venture Agreement** — It shall be valid during the entire period of the contract including the period of extension if any and the maintenance period after the work is completed.~~
 - ~~(iii) **Governing Laws** — The Joint Venture Agreement shall in all respect be governed by and interpreted in accordance with Indian Laws.~~
 - ~~(iv) **Authorized Member** — Joint Venture members shall authorize one of the members on behalf of the Joint Venture firm to deal with the tender, sign the agreement or enter into contract in respect of the said tender, to receive payment, to witness joint measurement of work done, to sign measurement books and similar such action in respect of the said tender/contract. All notices/correspondences with respect to the contract would be sent only to this authorized member of the JV firm.~~
 - ~~(v) No member of the Joint Venture firm shall have the right to assign or transfer the interest right or liability in the contract without the written consent of the other members and that of the employer in respect of the said tender/contract.~~
- ~~n) **Documents to be enclosed by the JV firm along with the tender:**~~
- ~~i. — In case one or more of the members of the JV firm is/are partnership firm(s), following documents shall be submitted:~~
 - ~~a. — Notary certified copy of the Partnership Deed,~~
 - ~~b. — Consent of all the partners to enter into the Joint Venture Agreement on a~~

stamp paper of appropriate value (in original).

~~e. Power of Attorney (duly registered as per prevailing law) in favor of one of the partners to sign the MOU and JV Agreement on behalf of the partners and create liability against the firm.~~

~~ii. In case one or more members is/are Proprietary Firm or HUF, the following documents shall be enclosed:~~

~~a. Affidavit on Stamp Paper of appropriate value declaring that his Concern is a Proprietary Concern and he is sole proprietor of the Concern OR he is in position of "KARTA" of Hindu Undivided Family and he has the authority, power and consent given by other partners to act on behalf of HUF.~~

~~iii. In case one or more members is/are limited companies, the following documents shall be submitted:~~

~~a. Notary certified copy of resolutions of the Directors of the Company, permitting the company to enter into a JV agreement, authorizing MD or one of the Directors or Managers of the Company to sign MOU, JV Agreement, such other documents required to be signed on behalf of the Company and enter into liability against the company and/or do any other act on behalf of the company.~~

~~b. Copy of Memorandum and articles of Association of the Company.~~

~~e. Power of Attorney (duly registered as per prevailing law) by the Company authorizing the person to do/act mentioned in the para (a) above.~~

~~o) All the members of the JV shall certify that they have not been black listed or debarred by MCGM from participation in tenders/contract in the past either in their individual capacity or the JV firm or partnership firm in which they were members / partners.~~

~~p) Credentials & Qualifying criteria: Technical and financial eligibility of the JV firm shall be adjudged based on satisfactory fulfillment of the following criteria:~~

~~**Technical eligibility criteria:** In case of Work involving single discipline, the Lead member of the JV firm shall meet at least 35% requirement of technical capacity as stipulated in tender document.~~

OR

~~In case of composite works (e.g. works involving more than one distinct component such as Civil Engineering works, M&E works, Electrical works, etc. and in the case of major bridges, substructure and superstructure etc.), atleast one member should have satisfactorily completed 35% of the value of any one component of the project work so as to cover all the components of project work or any member having satisfactorily completed 35% of the value of work of each component during last seven financial years.~~

~~**In such cases, what constitutes a component in a composite work shall be clearly defined as part of the tender condition without any ambiguity.**~~

~~**Financial eligibility criteria:** The contractual payments received by the JV firm or the arithmetic sum of contractual payments received by all the members of JV firm in any one of the previous three financial years and shall be at least **100% of the estimated value** of the work as mentioned in the tender.~~

84. **Compensation for delay:**

If the Contractor fails to complete the works and clear the site on or before the Contract or extended date(s) / period(s) of completion, he shall, without prejudice to any other right or remedy of Municipal Corporation on account of such breach, pay as agreed compensation, amount calculated as stipulated below (or such smaller amount as may be fixed by the Engineer) on the contract value of the whole work or on the contract value of the time or group of items of work for which separate period of completion are given in the contract and of which completion is delayed for every week that the whole of the work of item or group of items of work concerned remains uncompleted, even though the contract as a whole be completed by the contract or the extended date of completion. For this purpose the term 'Contract Value' shall be the value of the work at Contract Rates as ordered including the value of all deviations ordered:

- Completion period for projects (originally stipulated or as extended) not exceeding 6 months :**to the extent of maximum 1 percent per week.**
- Completion period for projects (originally stipulated or as extended) exceeding 6 months and not exceeding 2 years: **to the extent of maximum ½ percent per week.**
- Completion period for projects (originally stipulated or as extended) exceeding 2 years: **to the extent of maximum ¼ percent per week.**

When the delay is not a full week or in multiple of a week but involves a fraction of a week the compensation payable for that fraction shall be proportional to the number of days involved.

Provided always that the total amount of compensation for delay to be paid this condition shall not exceed the undernoted percentage of the Contract Value of the item or group of items of work for which a separate period of completion is given.

- (i) Completion period (as originally stipulated or as extended) not exceeding 6 months: **10 percent.**
- (ii) Completion period (as originally stipulated or as extended) exceeding 6 months and not exceeding 2 years: **7½ percent.**
- (iii) Completion period (as originally stipulated or as extended) exceeding 2 years: **5 percent.**

The amount of compensation may be adjusted set off against any sum payable to the contractor under this or any other contract with the Municipal Corporation.

85. **Action And Compensation Payable In Case Of Bad Work And Not Done As Per Specifications**

All works under or in course of execution or executed in pursuance of the contract, shall at all times be open and accessible to the inspection and supervision of the Engineer-in-charge, his authorized subordinates in charge of the work and all the superior officers, officer of the Vigilance Department of the MCGM or any organization engaged by the MCGM for Quality Assurance and the contractor shall, at all times, during the usual working hours and at all other times at which reasonable notice of the visit of such officers has been given to the contractor, either himself be present to receive orders and instructions or have a responsible agent duly accredited in writing, present for that purpose. Orders given to the Contractor's agent shall be considered to have the same force as if they had been given to the contractor himself.

If it shall appear to the Engineer-in-charge or his authorized subordinates in-charge of the work or to the officer of Vigilance Department, that any work has been executed with unsound, imperfect or unskillful workmanship or with materials of any inferior description, or that any materials or articles provided by him for the execution of the work are unsound or of a quality inferior to that contracted for or otherwise not in accordance with the contract, the contractor shall, on demand in writing which shall be made within twelve months of the completion of the work from the Engineer-in-Charge specifying the work, materials or articles complained of notwithstanding that the same may have been passed, certified and paid for forthwith rectify, or remove and reconstruct the work so specified in whole or in part, as the case may require or as the case may be, remove the materials or articles so specified and provide other proper and suitable materials or articles at his own charge and cost. In the event of the failing to do so within a period specified by the Engineer-in-Charge in his demand aforesaid, then the contractor shall be liable to pay compensation at the same rate as under clause 8.e. of the general condition of contract in section 9 of tender document (for Compensation for delay) for this default. In such case the Engineer-in Charge may not accept the item of work at the rates applicable under the contract but may accept such items at reduced rates as the Engineer in charge may consider reasonable during the preparation of on account bills or final bill if the item is so acceptable without detriment to the safety and utility of the item and the structure or he may reject the work outright without any payment and/or get it and other connected and incidental items rectified, or removed and re-executed at the risk and cost of the contractor. Decision of the Engineer-in- Charge to be conveyed in writing in respect of the same will be final and binding on the contractor.

If the penalization amount exceeds maximum limit with respect to Clause 8.e of Standard General Conditions of Contract, then a show cause notice shall necessarily be issued to the contract as to why the contract should not be terminated.

86. Contractors remain liable to pay compensation:

In any case in which any of the powers conferred upon the Engineer In-charge by the **relevant clauses** in documents that form a part of contract as exercised or is exercisable in the event of any future case of default by the Contractor, he is declared liable to pay compensation amounting to the whole of his security deposit. The liability of the Contractor for past and future compensation shall remain unaffected.

In the event of the Executive Engineer taking action against these **relevant clauses**, he may, if he so desires, take possession of all or any tools and plant, materials and stores in or upon the work of site

thereof or belonging to the Contractor or procured by him and intended to be used for the execution of the work or any part thereof paying or allowing for the same in account at the contract rates, or in the case of contract rates not being applicable at current market rates to be certified by the Executive Engineer, may after giving notice in writing to the Contractor or his staff of the work or other authorized agent require him to remove such tools and plants, materials or stores from the premises within a time to be specified in such notice and in the event of the Contractor failing to comply with any such requisition, the Executive Engineer may remove them at the contractors expense of sell them by auction or private sell on account of the Contractor at his risk in all respects and certificate of the Executive Engineer as to the expense of any such removal and the amount of the proceeds an expense of any such sell be final and conclusive against the Contractor.

87. No Claim To Any Payment Or Compensation Or Alteration In Or Restriction Of Work

- a) If at any time after the execution of contract documents, the Engineer shall for any reason whatsoever, desires that the whole or any part of the works specified in the Tender should be suspended for any period or that the whole or part of the work should not be carried out, at all, he shall give to the Contractor a Notice in writing of such desire and upon the receipt of such notice, the Contractor shall forthwith suspend or stop the work wholly or in part as required after having due regard to the appropriate stage at which the work should be stopped or suspended so as not to cause any damage or injury the work already done or endanger the safety thereof, provided that the decision of the Engineer as to the stage at which the work or any part of it could be or could have been safely stopped or suspended shall be final and conclusive against the contractor.

The Contractor shall have no claim to any payment or compensation whatsoever by reason of or in pursuance of any notice as aforesaid, on account of any suspension, stoppage or curtailment except to the extent specified hereinafter.

- b) Where the total suspension of Work Order as aforesaid continued for a continuous period exceeding 90 days the contractor shall be at liberty to withdraw from the contractual obligations under the contract so far as it pertains to the unexecuted part of the work by giving 10 days prior notice in writing to the Engineer within 30 days of the expiry of the said period of 90 days, of such intention and requiring the Engineering to record the final measurement of the work already done and to pay final bill. Upon giving such Notice, the Contractor shall be deem to have been discharged from his obligations to complete the remaining unexecuted work under his contract. On receipt of such notice the Engineer shall proceed to complete the measurement and make such payment as may be finally due to the contractor within a period of 90 days from the receipt of such Notice in respect of the work already done by the contractor. Such payment shall not in any manner prejudice the right of the contractor to any further compensation under the remaining provisions of this clause.
- c) Where the Engineer required to Contractor to suspend the work for a period in excess of 30 days at any time or 60 days in the aggregate, the Contractor shall be entitled to apply to the Engineer within 30 days of the resumption of the work after such suspension for payment of compensation to the extent of pecuniary loss suffered by him in respect of working machinery

remained ideal on the site of on the account of his having an to pay the salary of wages and labour engaged by him during the said period of suspension provided always that the contractor shall not be entitled to any claim in respect of any such working machinery, salary or wages for the first 30 days whether consecutive or in the aggregate or such suspension or in respect of any such suspension whatsoever occasion by unsatisfactory work or any other default on his part, the decision of the Engineer in this regard shall be final and conclusive against the contractor.

88. Contractor to supply plant, ladder, scaffolding, etc and is liable for damages arising from non-provision of lights, fencing, etc.

The Contractor shall supply at his own cost all material, plant, tools, appliances, implements, ladders, cordage, tackle scaffolding and temporary works requisite or proper for the proper execution of the work, whether, in the original altered or substituted form and whether included in the specification of other documents forming part of the contract or referred to in these conditions or not and which may be necessary for the purpose of satisfying or complying with the requirements of the Eng-In-Charge as to any matter as to which under these conditions is entitled to be satisfied, or which is entitled to require together with the carriage therefore to and from the work.

The Contractor shall also supply without charge, the requisite number of person with the means and materials necessary for the purpose of setting out works and counting, weighing and assisting in the measurements of examination at any time and from time to time of the work or materials, failing which the same may be provided by the Engineer In-charge at the expense of the contractor and the expenses may be deducted from any money due to the contractor under the contract or from his security deposit or the proceeds of sale thereof, or offers sufficient portion thereof.

The contractor shall provide all necessary fencing and lights required to protect the public from accident and shall also be bound to bear the expenses of defence of every suit, action or other legal proceedings, that may be brought by any person for injury sustained owing to neglect of the above precautions and to pay any damages and cost which may be awarded in any such suit action or proceedings to any such person or which may with the consent of the contractor be paid for compromising any claim by any such person.

89. Prevention of Fire :

The contractor shall not set fire to any standing jungle, trees, brushwood or grass without a written permit from the Engineer In-charge. When such permit is given, and also in all cases when destroying cut or dug up trees brushwood, grass, etc., by fire, the contractor shall take necessary measure to prevent such fire spreading to or otherwise damaging surrounding property. The Contractor shall make his own arrangements for drinking water for the labour employed by him.

90. Compensation for all damages done intentionally or unintentionally by contractor's labour whether in or beyond the limits of MCGM property including any damage caused by spreading the fire shall be estimated by the Engineer In-charge or such other officer as he may appoint and the estimate of the Engineer in-charge to the decision of the Dy. Chief Engineer on appeal shall be final and the contractor shall be bound to pay the amount of the assessed compensation on demand failing which the same will be recovered from the Contractor as damages or deducted by the Engineer In-charge

from any sums that may be due or become due from MCGM to contractor under this Contract or otherwise. Contractor shall bear the expenses of defending any action or other legal proceedings that may be brought to prevent the spread of fire and he shall pay any damages and costs that may be awarded by the Court in consequence.

91. In the case of Tender by partners, any change in the constitution of the firm shall be forthwith, notified by the contractor through the Engineer In-charge for his information.

92. Action where no specifications: In the case of any class of work for which there is no such specifications, such works shall be carried out in accordance with the specifications and in the event of there being no such specifications, then in such case, the work shall be carried out in all respects in accordance with all instructions and requirements of the Engineer In- charge.

93. Safety and medical help :

(i) The Contractor shall be responsible for and shall pay the expenses of providing medical help to any workmen who may suffer a bodily injury as a result of an accident. If such expenses are incurred by MCGM, the same shall be recoverable from the contractor forthwith and be included without prejudice to any other remedy of MCGM from any amount due or that may become due to the Contractor.

(ii) The contractor shall provide necessary personal safety equipment and first-aid box for the use of persons employed on the site and shall maintain the same in condition suitable for immediate use at any time.

(iii) The workers shall be required to use the safety equipment's so provided by the contractor and the contractor shall take adequate steps to ensure the proper use of equipment's by those concerned.

(iv) When the work is carried on in proximity to any place where there is risk or drawing all necessary equipment's shall be provided and kept ready for use and all necessary steps shall be taken for the prompt rescue of any person in danger.

94. No compensation shall be allowed for any delay caused in the starting of the work on account of acquisition of land or in the case of clearance of works, on account of any delay in according to sanction of estimates.

95. Anti-malaria and other health measures:

Anti-Malaria and other health measures shall be taken as directed by the Executive Health Officer of MCGM. Contractor shall see that mosquito genic conditions are created so as to keep vector population to minimum level. Contractor shall carry out anti-malaria measures in the area as per the guidelines issued by the Executive Health Officer of MCGM from time to time.

In case of default, in carrying out prescribed anti-malaria measures resulting in increase in malaria incidence, contractor shall be liable to pay MCGM on anti- malaria measures to control the situation in addition to fine.

SECTION 10

SPECIFICATIONS & SELECTION OF MATERIAL

SPECIFICATIONS & SELECTION OF MATERIAL

The tender is prepared on the basis of Unified Schedule of Rates and specifications 2018. The specifications of the items of USOR are available on MCGM portal <http://portal.mcg.gov.in> under the Tender tab. Hence the deserving contractor shall either download the same from MCGM portal or the same may be collected in the soft copy format at the time of purchasing the tender from this office.

SELECTION OF MATERIAL

- 1) All materials brought on the site of work and meant to be used in the same, shall be the best of their respective kinds and to the approval of the Engineer. The Engineer or his representative will accept that the materials are really the best of their kinds, when it is proved beyond doubt that no better materials of the particular kind in question are available in the market.
- 2) The contractor shall obtain the approval of the Engineer of samples of all materials to be used in the works and shall deposit these samples with him before placing an order for the materials with the suppliers. The materials brought on the works shall conform in every respect to their approved samples. Fresh samples shall be deposited with the Engineer whenever the type or source of any material changes.
- 3) The contractor shall check each fresh consignment of materials as it is brought to the site of works to see that they conform in all respects to the Specifications of the samples approved by the Engineer, or both.
- 4) The Engineer will have the option to have any of the materials tested to find out whether they are in accordance with the Specifications and the Contractor will bear all expenses for such testing. All B bills, vouchers and test certificates, which in the opinion of the Engineer or his representative are necessary to convince him as to the quality of the materials or their suitability shall be produced for his inspection when required.
- 5) Any materials that have not been found to conform to the specifications will be rejected forthwith and shall be removed from the site by the contractor at his own cost within 24 hours.
- 6) The Engineer shall have power to cause the Contractors to purchase and use such materials from any particular source, as may in his opinion be necessary for the proper execution of the work.
- 7) Notwithstanding the source, the sand shall be washed using sand washing machine before use.
- 8) **Testing of all materials shall be carried, as per testing frequency specified in relevant specifications, standards, Quality assurance manual etc is mandatory. The testing of concrete used for structural works shall be tested for every pouring/casting day and as per relevant IS Codes provision. The testing of steel material used for structural works shall be done for every lot received on site and the same shall be submitted to MCGM before actual use on site.**

If adequate no. of tests are not carried out the corresponding pro-rata quantity payment will be withheld/recovered if inadvertently paid, at any stage of the contract.

SECTION 11
FRAUD AND CORRUPT
PRACTICES

FRAUD AND CORRUPT PRACTICES

- The Applicants and their respective officers, employees, agents and advisers shall observe the highest standard of ethics during the Bidding Process. Notwithstanding anything to the contrary contained herein, the Authority may reject an Application without being liable in any manner whatsoever to the Applicant if it determines that the Applicant has, directly or indirectly or through an agent, engaged in corrupt practice, fraudulent practice, coercive practice, undesirable practice or restrictive practice in the Bidding Process.
- Without prejudice to the rights of the Authority under relevant Clause hereinabove, if an Applicant is found by the Authority to have directly or indirectly or through an agent, engaged or indulged in any corrupt practice, fraudulent practice, coercive practice, undesirable practice or restrictive practice during the Bidding Process, such Applicant shall not be eligible to participate in any tender or RFQ issued by the Authority during a period of 2 (two) years from the date such Applicant is found by the Authority to have directly or indirectly or through an agent, engaged or indulged in any corrupt practice, fraudulent practice, coercive practice, undesirable practice or restrictive practice, as the case may be.
- For the purposes of this Clause, the following terms shall have the meaning hereinafter respectively assigned to them:
 - (A) “**corrupt practice**” means the offering, giving, receiving, or soliciting, directly or indirectly, of anything of value to influence the actions of any person connected with the Bidding Process (for avoidance of doubt, offering of employment to, or employing, or engaging in any manner whatsoever, directly or indirectly, any official of the Authority who is or has been associated in any manner, directly or indirectly, with the Bidding Process or the LOA or has dealt with matters concerning the Concession Agreement or arising there from, before or after the execution thereof, at any time prior to the expiry of one year from the date such official resigns or retires from or otherwise ceases to be in the service of the Authority, shall be deemed to constitute influencing the actions of a person connected with the Bidding Process); **or**

save and except as permitted under the relevant sub clause, engaging in any manner whatsoever, whether during the Bidding Process or after the issue of the LOA or after the execution of the Concession Agreement, as the case may be, any person in respect of any matter relating to the Project or the LOA or the Concession Agreement, who at anytime has been or is a legal, financial or technical adviser of the Authority in relation to any matter concerning the Project;
 - (B) “**fraudulent practice**” means a misrepresentation or omission of facts or suppression of facts or disclosure of incomplete facts, in order to influence the Bidding Process ;
 - (C) “**coercive practice**” means impairing or harming or threatening to impair or harm, directly or indirectly, any person or property to influence any person's participation or action in the Bidding Process;

- (D) **“undesirable practice”** means (i) establishing contact with any person connected with or employed or engaged by the Authority with the objective of canvassing, lobbying or in any manner influencing or attempting to influence the Bidding Process; or (ii) having a Conflict of Interest; and
- (E) **“Restrictive practice”** means forming a cartel or arriving at any understanding or arrangement among Applicants with the objective of restricting or manipulating a full and fair competition in the Bidding Process.
- (F) If the Employer/Financier determines that the Contractor has engaged in corrupt, fraudulent, collusive, coercive or obstructive practices, in competing for or in executing the Contract, then the Employer may, after giving 14 days’ notice to the Contractor, terminate the Contractor’s employment under the Contract and expel him from the Site, and the provisions of relevant Clause shall apply as if such expulsion had been made.
- (G) Should any employee of the Contractor be determined to have engaged in corrupt, fraudulent, collusive, coercive, or obstructive practice during the execution of the Works, then that employee shall be removed in accordance with relevant Clause.

For the purposes of this Sub-Clause:

- i. “Corrupt practice” is the offering, giving, receiving to soliciting, directly or indirectly, of anything of value to influence improperly the actions of another party;
- ii. “Another party” refers to a public official acting in relation to the procurement process or contract execution. In this context, “public official” includes Financier staff and employees of other organizations taking or reviewing procurement decisions.
- iii. “Fraudulent practice” is any act or omission, including a misrepresentation, that knowingly or recklessly misleads, or attempts to mislead, a party to obtain a financial or other benefit or to avoid an obligation;
- iv. “Collusive practice” is an arrangement between two or more parties designed to achieve an improper purpose, including to influence improperly the actions of another party;
- v. “Coercive practice” is impairing or harming, or threatening to impair or harm, directly or indirectly, any party or the property of the party to influence improperly the actions of a party;
- vi. “Obstructive practice” is deliberately destroying, falsifying, altering or concealing of evidence material to the investigation or making false statements to investigators in order to materially impede the Financier investigation into allegations of a corrupt, fraudulent, coercive or collusive practice; and/or threatening, harassing or intimidating any party to prevent it from disclosing its knowledge of matters relevant to the investigation or from pursuing the investigation; or

- vii. Acts intended to materially impede the exercise of the Financer’s inspection and audit rights provided.
- viii. “Party” refers to a public official; the terms “benefit” and “obligation” relate to the procurement process or contract execution; and the “act or omission” is intended to influence the procurement process or contract execution.
- ix. ”Parties” refers to participants in the procurement process (including public officials) attempting to establish bid prices at artificial, noncompetitive levels.
- x. A “party” refers to a participant in the procurement process or contract execution.

SECTION 12
PRE BID MEETING

PRE-BID MEETING

Pre-Meeting will be applicable for the works costing more than Rs. 25 Crores.

Pre-bid meeting of the interested parties shall be convened at the designated date, time and place. A maximum of three representatives of each Applicant shall be allowed to participate on production of authority letter from the Applicant.

During the course of Pre-bid meeting, the Applicants will be free to seek clarifications and make suggestions for consideration of the Authority. The Authority shall Endeavour to provide clarifications and such further information as it may, in its sole discretion, consider appropriate for facilitating a fair, transparent and competitive Bidding Process.

SECTION –13

LIST OF APPROVED BANKS

LIST OF APPROVED BANKS

The following Banks with their branches in Greater Mumbai and in suburbs up to Virar and Kalyan have been approved only for the purpose Banker's guarantee from 1997-98 onwards until further instructions.

The Bankers Guarantee issued by branches of approved Banks beyond Kal can be accepted only if the said Banker's Guarantee is countersigned by the branch of the same Bank, within the Mumbai Limit categorically endorsing said bankers Guarantee is binding on the endorsing Branch of the bank w limits and is liable to be on forced against the said branch of the Bank in case the contractor/supplier furnishing the bankers Guarantee.

List of approved Banks:-

A	SBI and its Subsidiary Banks
1	State Bank of India
B	Nationalized Banks
2	Allahabad Bank
3	Andhra Bank
4	Bank of Baroda
5	Bank of India
6	Bank of Maharashtra
7	Central Bank of India
8	Dena Bank
9	Indian Bank
10	Indian Overseas Bank
11	Oriental Bank of Commerce
12	Punjab National Bank
13	Punjab & Sindh Bank
14	Syndicate Bank.
15	Union Bank of India
16	United Bank of India
17	UCO Bank
18	Vijaya Bank
19	Corporation Bank
C	Scheduled Commercial Bank
20	Bank of Madura Ltd
21	Bank of Rajasthan Ltd
22	Banaras State Bank Ltd
23	Bharat Overseas bank
24	Catholic Syrian Bank Ltd
24A	City Union bank Ltd
25	Development Credit Bank

26	Dhanalaxmi Bank Ltd.
27	Federal Bank Ltd
28	Indsind Bank Ltd
29	I.C.I.C.I. Banking Corporation Ltd
30	Global Trust Bank Ltd.
31	Jammu & Kashmir Bank Ltd.
32	Karnataka Bank Ltd.
33	Karur Vysya Bank Ltd.
34	Laxmi Vilas Bank Ltd.
35	Nedugundi Bank Ltd.
36	Ratnakar Bank Ltd.
37	Sangli Bank Ltd.
38	South Indian Bank Ltd
39	S.B.I. Corporation & Int Bank Ltd.
40	Tamilnadu Mercantile Bank Ltd.
41	United Western Bank Ltd.
42	Vysya Bank Ltd.
D	Scheduled Urban Co-op Banks
43	Abhyudaya Co-op Bank Ltd
44	Bassein Catholic Co-op Bank Ltd
45	Bharat Co-op Bank Ltd
46	Bombay Mercantile Co-op Bank Ltd
47	Cosmos Co-op Bank Ltd
48	Greater Mumbai Co-op Bank Ltd
49	Janata Sahakari Bank Ltd
50	Mumbai District Central Co-op Bank Ltd
51	Maharashtra State Co-op Bank Ltd
52	New India Co-op Bank Ltd
53	North Canara GSB Co-op Bank Ltd
54	Rupee Co-op Bank Ltd
55	Sangli Urban Co-op Bank Ltd
56	Saraswat Co-op Bank Ltd
57	Shamrao Vitthal Co-op Bank Ltd
58	Mahanagar Co-op Bank Ltd
59	Citizen Bank Ltd.
60	Yes Bank Ltd.
E	Foreign Banks
61	ABM AMRO (NY) Bank
62	American Express Bank Ltd.
63	ANZ Grinlays Bank Ltd
64	Bank of America N.T. & S.A.

65	Bank of Tokyo Ltd
66	Bankindosuez
67	Banque Nationale de Paris.
68	Barclays Bank
69	City Bank N.A.
70	Hongkong & Shanghai Banking Corporation.
71	Mitsui Taiyokbe Bank Ltd
72	Standard Chartered Bank
73	Cho hung Bank

SECTION -14
APPENDIX

FORM OF TENDER

To,
The Municipal Commissioner for Greater Mumbai

Sir,

I/ We have read and examined the following documents relating to the construction of

- a. Notice inviting tender.
- b. Directions to tenderers (General and special)
- c. General condition of contract for Civil Works of the Municipal Corporation of Greater Mumbai as amended up to date.
- d. Relevant drawings
- e. Specifications.
- f. Special directions
- g. Annexure A and B.
- h. Bill of Quantities and Rates.

1A. I/We _____
(full name in capital letters, starting with surname), the Proprietor/ Managing Partner/
Managing Director/ Holder of the Business, for the establishment / firm / registered
company, named _____ herein _____ below, do hereby
offer to.....
.....
.....
.....

Referred to in the specifications and schedule to the accompanying form of contract of the rates entered in the schedule of rates sent herewith and signed by me/ us” (strike out the portions which are not applicable).

- 1B. I/We do hereby state and declare that I/We, whose names are given herein below in details with the addresses, have not filled in this tender under any other name or under the name of any other establishment /firm or otherwise, nor are we in any way related or concerned with the establishment /firm or any other person, who have filled in the tender for the aforesaid work.”
- 2. I/We hereby tender for the execution of the works referred to in the aforesaid documents, upon the terms and conditions, contained or referred to therein and in accordance with the specifications designs, drawings and other relevant details in all respects.
 - * At the rates entered in the aforesaid Bill of Quantities and Rates.
- 3. According to your requirements for payment of Earnest Money amounting to

Rs. _____ /-(Rs. _____)

I/We have deposited the amount through online payment gateways with the C.E. of the Corporation not to bear interest

4. I/We hereby request you not to enter into a contract with any other person/s for the execution of the works until notice of non/acceptance of this tender has first been communicated to me/us, and in consideration of yours agreeing to refrain from so doing I/we agree not to withdraw the offer constituted by this tender before the date of communication to me/us of such notice of non/acceptance, which date shall be not later than ten days from the date of the decision of the Standing Committee or Education Committee of the Corporation, as maybe required under the Mumbai Municipal Corporation Act, not to accept this tender.(Subject to condition 5 below).
5. I/We also agree to keep this tender open for acceptance for a period of 180 days from the date fixed for opening the same and not to make any modifications in its terms and conditions which are not acceptable to the Corporation.
6. I/We agree that the Corporation shall, without prejudice to any other right or remedy, be at liberty to forfeit the said earnest money absolutely, if.
 - a. I/We fail to keep the tender open as aforesaid.
 - b. I/We fail to execute the formal contract or make the contract deposit when called upon to do so.
 - c. I/we do not commence the work on or before the date specified by the Engineer in his work order.
7. I/We hereby further agree to pay all the charges of whatsoever nature in connection with the preparation, stamping and execution of the said contract.
8. I/We further agree that, I/we shall register ourselves as 'Employer' with the Bombay Iron and Steel Labour Board' and fulfill all the obligatory provisions of Maharashtra Mathadi, Hamal and other Manual workers (Regulation of Employment and Welfare) Act 1969 and the Bombay Iron and Steel unprotected workers Scheme 1970.
9. "I/We..... have failed in the accompanying tender with full knowledge of liabilities and, therefore, we will not raise any objection or dispute in any manner relating to any action, including forfeiture of deposit and blacklisting, for giving any information, which is found to be incorrect and against the instructions and directions given in this tender.
10. "I/We further agree and undertake that in the event it is revealed subsequently after the allotment of work/contract to me/us, that any information given by me/us in this tender is false or incorrect, I/We shall compensate the Municipal Corporation of Greater Mumbai for any such losses or inconvenience caused to the Corporation in any manner and will not resist any claim for such compensation on any ground whatsoever. I/we agree and undertake that I/we shall not claim in such case any amount by way of damages or compensation for cancellation of the contract given to me/us or any work assigned to me/us or is withdrawn by the Corporation,"

Address:

Yours faithfully,

.....

.....

Digital Signature of the Tenderer or the Firm

1.....

2.....

3.....

4.....

5.....

Full Name and private residential address
of all the partners constituting the Firm

A/c No.....

1.

Name of Bank.....

2.

Name of Branch.....

3.

Vender No.....

4.

5.

AGREEMENT FORM

Tender / Quotation

dated.....20...

Standing Committee/Education Committee Resolution No.

CONTRACT FOR THE WORKS.....

.....
This agreement made this day of Two thousand

Between inhabitants of Mumbai,

carrying on business at.....

..... in Mumbai under the

style and name of M/s.

Hereinafter called "the contractor of the one part and Shri..... the

Director (E.S.&P.) (hereinafter called "The Commissioner" in which expression are included unless the

inclusion is inconsistent with the context, or meaning thereof, his successor or successors for the time

being holding the office of Director (E,S.& P)of the second part and the Municipal Corporation of Greater

Mumbai (hereinafter called "the Corporation") of the third part, WHEREAS the contractor has tendered

for the construction, completion and maintenance of the works described above and his ten- der has been

accepted by the Commissioner (with the approval of the Standing Committee/Education Committee of the

Corporation NOW THIS AGREEMENT WITNESSETH as follows:-

- 1) In this agreement words and expressions shall have the same meanings as are respectively assigned to them in the General Conditions of Contract for works hereinafter referred to:-
- 2) The following documents shall be deemed to form and be read and constructed as a part of this agreement viz.
 - a) The letter of Acceptance
 - b) The Bid:
 - c) Addendum to Bid; if any
 - d) Tender Document
 - e) The Bill of Quantities:
 - f) The Specification:
 - g) Detailed Engineering Drawings
 - h) Standard General Conditions of Contracts (GCC)
 - i) All correspondence documents between bidder and MCGM
- 3) In consideration of the payments to be made by the Commissioner to the contractor as hereinafter mentioned the contractor hereby covenants with the Commissioner to construct, complete and maintain the works in conformity in all respects with the provision of the contract.
- 4) The Commissioner hereby covenants to pay to the Contractor in consideration of the construction, completion and maintenance of the works the contract sum, at times and in the manner prescribed by the contract.

IN WITNESS WHERE OF the parties hereto have caused their respective common seals to be

herein to affixed (or have hereunto set their respective hands and seals) the day and year above written.

Signed, Sealed and delivered by the Contractors

.....
.....
.....

In Presence of

.....
.....

Trading under the name and style of

.....
.....

Full Name

Address

Contractors

Signed by the Director (ES&P) in the presence of Ex.....City/WS/ES

.....
.....

Director (ES&P)

The Common Seal of the Municipal Corporation of Greater Mumbai was hereunto affixed on the20 in the presence of two members of the Standing Committee.

- | | |
|----|----|
| 1. | 1. |
| 2. | 2. |

And in the presence of the Municipal Secretary

Municipal Secretary

ANNEXURE 'A'

Name of the Work :	CT-60 work of construction of RCC box drain of size 4m x 2m along Sion- Mahim link road from piwala Bunglow up to T-Junction in G/N ward.
---------------------------	---

1.	Engineer for this work	Chief Engineer (S.W.D.)
		Dy.Ch. Engineer (S.W.D.) City.
		Executive Engineer (S.W.D.) City Zone- II

2	Estimated Cost of Tender	
Sr	Description of Work	Total Amount Rs.
I	Civil Work	Rs. 33,99,12,418.00/-
II	Electrical Work	-----
II I	Total Amount	Rs. 33,99,12,418.00/-

3	Earnest Money (1% of Estimated Cost)	Rs. 33,99,200/-
---	--------------------------------------	------------------------

4	Time Period	
	1. Contract as a whole period Completion	6 Months (Excluding Monsoon)
	Part or Group of items-- Not Applicable	
	i.	Not Applicable

5. Percentage to be charged as supervision charges for the work got executed through other means **10 percent.**

6. The "Actual cost of the work" shall mean in the case of percentage rate contracts the actual cost of

the work executed at the rates as mentioned in the Contract Schedule adjusted by the Contractor's percentage rate and cost of extra and excess, but excluding the cost on account of Water Charges and Sewerage Charges if any, payable by the contractor and also excluding cost on account of price variation claims as provided in price variation clause as amended up to date.

7. In case of item rate contracts the actual cost calculated for the work executed at the rates mentioned in the contract schedule for different items including cost of excess and extra items of the work excluding the cost of water charges and sewerage charges if any, payable by the contractor and excluding cost on account of price variation claims as provided in extra excess conditions as amended up to date.
8. In case of lump sum contract the cost of the work actually carried out as per break up and programme of the work and the schedule of payment included in the contract including cost of any excess and/or extra items, of the work, excluding the cost on account of water charges and sewerage charges and also excluding cost on account of price variation claims as provided in extra excess conditions as amended up to date.

Annexure-B

PRE-CONTRACT INTEGRITY PACT

(On Rs. 500/- Stamp Paper)

The Bidder commits himself to take all measures necessary to prevent corrupt practices, unfair means and illegal activities during any stage of his bid or during any pre-contract or post-contract stage in order to secure the contract or in furtherance to secure it and in particular commits himself to the following:-

- 1.** The Bidder will not offer, directly or through intermediaries, any bribe, gift, consideration, reward, favour, any material or immaterial benefit or other advantage, commission, fees, brokerage or inducement to any official of the MCGM, connected directly or indirectly with the bidding process, or to any person, organization or third party related to the contract in exchange for any advantage in the bidding, evaluation, contracting and implementation of the Contract.
- 2.** The Bidder further undertakes that he has not given, offered or promised to give, directly or indirectly any bribe, gift, consideration, reward, favour, any material or immaterial benefit or other advantage, commission, fees, brokerage or inducement to any official of the MCGM or otherwise in procuring the Contract or forbearing to do or having done any act in relation to the obtaining or execution of the Contract or any other Contract with the Government for showing or forbearing to show favour or disfavour to any person in relation to the Contract or any other Contract with the Government.
- 3.** The Bidder will not collude with other parties interested in the contract to impair the transparency, fairness and progress of the bidding process, bid evaluation, contracting and implementation of the contract.
- 4.** The Bidder will not accept any advantage in exchange for any corrupt practice, unfair means and illegal activities.
- 5.** The Bidder, either while presenting the bid or during pre-contract negotiations or before signing the contract, shall disclose any payments he has made, is committed to or intends to make to officials of the MCGM or their family members, agents, brokers or any other intermediaries in connection with the contract and the details of services agreed upon for such payments.
- 6.** The Bidder shall not use improperly, for purposes of competition or personal gain, or pass on to others, any information provided by the MCGM as part of the business relationship, regarding plans, technical proposals and business details, including information contained in any electronic data carrier. The Bidder also undertakes to exercise due and adequate care lest any such information is divulged.
- 7.** The Bidder commits to refrain from giving any complaint directly or through any other manner without supporting it with full and verifiable facts.
- 8.** The Bidder shall not instigate or cause to instigate any third person to commit any of the actions mentioned above.
- 9.** The Bidder and their respective officers, employees, agents and advisers shall observe the highest

standard of ethics during the Bidding Process. Notwithstanding anything to the contrary contained herein, the Authority may reject an Application without being liable in any manner whatsoever to the Applicant if it determines that the Applicant has, directly or indirectly or through an agent, engaged in corrupt practice, fraudulent practice, coercive practice, undesirable practice or restrictive practice in the Bidding Process

For the purposes of this Clause 9, the following terms shall have the meaning herein after respectively assigned to them:

1. “fraudulent practice” means a misrepresentation or omission of facts or suppression of facts or disclosure of incomplete facts, in order to influence the Bidding Process ;
2. “coercive practice” means impairing or harming or threatening to impair or harm, directly or indirectly, any person or property to influence any persons participation or action in the Bidding Process;
3. “undesirable practice” means (i) establishing contact with any person connected with or employed or engaged by the Authority with the objective of canvassing, lobbying or in any manner influencing or attempting to influence the Bidding Process; or (ii) having a Conflict of Interest; and
4. “restrictive practice” means forming a cartel or arriving at any understanding or arrangement among Applicants with the objective of restricting or manipulating a full and fair competition in the Bidding Process.

Signature of Tenderer/Bidder

Annexure- C

(On Rs. 500/- Stamp Paper)

DECLARATION CUM INDEMNITY BOND

I, _____ of _____, do hereby declared and undertake as under.

1. I declare that I have submitted certificates as required to Executive engineer (Monitoring) at the time of registration of my firm/company _____ and there is no change in the contents of the certificates that are submitted at the time of registration.
2. I declare that I _____ in capacity as Manager/Director/Partners/Proprietors of _____ has not been charged with any prohibitory and /or penal action such as banning (for specific time or permanent)/de-registration or any other action under the law by any Government and/or Semi Government and/or Government undertaking.
3. I declare that I have perused and examined the tender document including addendum, condition of contract, specifications, drawings, bill of quantity etc. forming part of tender and accordingly, I submit my offer to execute the work as per tender documents at the rates quoted by me in capacity as _____ of _____.
4. I further declare that if I am allotted the work and I failed to carry out the allotted work in accordance with the terms and conditions and within the time prescribed and specified, MCGM is entitled to carry out the work allotted to me by any other means at my risk and cost, at any stage of the contract.
5. I also declare that I will not claim any charge/damages/compensation for non availability of site for the contract work at any time.
6. I declare that I will positively make the arrangements of the required equipment on the day of commencement or with respect to the progress of the work in phases, as per the instructions of site in charge

Signature of Tenderer/Bidder

BANKERS GURANTEE IN LIEU OF CONTRACT DEPOSIT

THIS INDENTURE made this _____ day of _____ BETWEEN

THE _____ BANK incorporated under the English/Indian Companies Acts and carrying on business in Mumbai (hereinafter referred to as 'the bank' which expression shall be deemed to include its successors and assigns) of the first part _____ inhabitants carrying on business at _____ in Mumbai under the style and name of M/s. _____ (hereinafter referred to as 'the consultant') of the second part Shri. _____.

THE MUNICIPAL COMMISSIONER FOR GREATER MUMBAI (hereinafter referred to as 'the commissioner' which expression shall be deemed, also to include his successor or successors for the time being in the said office of Municipal Commissioner) of the third part and THE MUNICIPAL CORPORATION OF GREATER MUMBAI (hereinafter referred to as 'the Corporation') of the fourth part WHEREAS the consultants have submitted to the Commissioner tender for the execution of the work of " _____ and the terms of such tender /contract require that the consultants shall deposit with the Commissioner as/contract deposit/ earnest money and /or the security a sum of Rs.____(Rupees____)AND WHEREAS if and when any such tender is accepted by the Commissioner, the contract to be entered into in furtherance thereof by the consultants will provide that such deposit shall remain with and be appropriated by the Commissioner towards the Security - deposit to be taken under the contract and be redeemable by the consultants, if they shall duly and faithfully carry out the terms and provisions of such contract and shall duly satisfy all claims properly chargeable against them there under AND WHEREAS the consultants are constituents of the Bank and in order to facilitate the keeping of the accounts of the consultants, the Bank with the consent and concurrence of the consultants has requested the Commissioner to accept the undertaking of the Bank hereinafter contained, in place of the contractors depositing with the Commissioner the said sum as earnest money and /or security as aforesaid AND WHEREAS accordingly the Commissioner has agreed to accept such undertaking NOW THIS AGREEMENT WITNESSES that in consideration of the premises, the Bank at the request of the consultants (hereby testified) UNDERTAKES WITH the commissioner to pay to the commissioner upon demand in writing , whenever required by him , from time to time , so to do , a sum not exceeding in the whole Rs. _____ (Rupees _____) under the terms of the said tender and /or the contract .The B.G. Is valid upto____”Notwithstanding anything what has been stated above, our liability under the above guarantee is restricted to Rs. _____ only and guarantee shall remain in force upto _____ unless the demand or claim under this guarantee is made on us in writing on or before _____ all your right under the above guarantee shall be forfeited and we shall be released from all liabilities under the guarantee thereafter”

IN WITNESS WHEREOF WITNESS

(1) _____

Name _____

address _____

WITNESS (2) _____

Name and _____ the duly constituted Attorney Manager

address _____

the Bank and the said Messer's _____

(Name of the Bank)

WITNESS(1) _____

Name and _____

address _____

WITNESS(2) _____

Name and _____

For Messer's _____

address _____

have here into set their respective hands the day and year first above written.

The amount shall be inserted by the Guarantor, representing the Contract Deposit in Indian Rupees.

Annexure –D

Rate Analysis

Format for Rate Analysis									
Sr.No.	Code No.	Item Description	Unit	Quantity	Rate	Amount	GST %	GST Amount	Amount Including GST
A	MA	Material							
B	LB	Labour							
C	HC	Hiring Charges of Equipments and Machineries.							
							Total GST (D)		
E		Total(A+B+C)							
F		Add for profits & Overheads on E							
G		Total Cost (D+E+F)							
H		Per Unit Cost.							

Sign and seal of the Tenderer

PROFORMA

PROFORMA-I

The List of similar works as stated in Para 'A' of Post Qualification during last Seven years:-

PROFORMA-I					
Sr.	Name of Project	Name of Employer	Stipulated date of Completion	Actual Date of Completion	Actual Cost of Work done
1	2	3	4	5	6

Note:

- a) Scanned Attested Copies of Completion/Performance certificates from the Engineer-in-Charge for each work should be annexed in the support of information furnished in the above Proforma.
- b) Works shall be grouped financial year-wise.

PROFORMA-II

Yearly Turnover of Civil Engineering Construction works during last five years.

PROFORMA-II					
Sr	Financial Year	Annual Turnover of Civil Engineering works	Updated value to Current year	Average of last 5 years	Page No.
1					
2					
3					
4					
5					
TOTAL					

Note: The above figures shall tally with the Audited Balance Sheets uploaded by The tenderers duly certified by Chartered Accountant.

PROFORMA-III:-

At least Similar work, as stated in Para 'A' of Post Qualification.

PROFORMA-III							
Name of the project	Name of the Employer	Cost of the Project	Date of issue of Work Order	Stipulated Date of Completion	Actual Date of Completion	Actual cost of work done	Remarks explaining reasons for delay , if any
1	2	3	4	5	6	7	8

Note: Scanned Attested Copies of Completion/Performance certificates from the Engineer-in-Charge for each work should be annexed in the support of information furnished in the above Proforma.

PERSONNEL : PROFORMA-IV

PROFORMA-IV					
Sr.	Post	Name	Qualification	Work Experience	
		(Prime Candidate /Alternate)		No. of years	Name of Project
1	Project Manager				
2	Quality Control Engineer				
3	Site Engineer				
4	Site Supervisor				

MACHINERY :(For Special Work only)

PROFORMA-V/A			
Sr.	Equipment	Number	Owned/Leased/Assured Access
1	2	3	4

PROFORMA-V/B

Sr.	Equipment	Number	Owned
1	2	3	4

Note: The tenderers shall furnish/upload the requisite Scanned Attested documents of Ownership/leased of Machineries. The undertaking from the suppliers will not be accepted.

PROFORMA-VI/A : Details of Existing Commitments and Ongoing Works**PROFORMA-VI/A**

Description of the Work	Place	Contract No. & Date	Name & Address of the Employer	Value of Contract in Rs.	Scheduled date of Completion	Value of work remaining to be completed	Anticipated date of completion
1	2	3	4	5	6	7	8

Note: Scanned Attested Copies of Completion/Performance certificates from the Engineer-in-Charge for each work should be annexed in the support of information furnished in the above Proforma.

PROFORMA-VI/B : Details of works for which bids are already uploaded-**PROFORMA-VI/B**

Description of the Work	Place	Name & Address of the Employer	Value of Contract in Rs.	Time Period	Date on which decision is expected	Remarks
1	2	3	4	5	6	7

Note: Scanned Attested Copies of certificates from the Engineer-in-Charge for each work should be annexed in the support of information furnished in the above Proforma.

PROFORMA-VII : LITIGATION HISTORY

Other Party (ies)	Employer	Cause of Dispute	Amount involved.	Remarks showing Present Status.
1	2	3	4	5

Annexure –E

Note: For this subject work, all guidelines are mentioned in circular u/no. MGC/F/6342, dated 05/05/2018 will be strictly applicable.

Annexure –F

Note: For this subject work, all guidelines are mentioned in circular u/no. MGC/F/6342, dated 05/05/2018 will be strictly applicable.

Annexure –G

- **List of Approved Asphalt Plants:**

Tenderer(s) shall arrange to bring asphalt mixes from approved plants registered with M.C.G.M., during the execution of the work. **The valid list of approved asphalt plants at “the time of execution of works” to be obtained from the Dy.Ch.Engineer (Roads)City office.**

The Municipal Site Engineer to ensure the validity of registration certificate of asphalt plant and compliance of conditions laid down in the registration certificate issued to the asphalt plant owner before receiving asphalt mixes.

- **List of approved manufacturer of interlocking paver blocks**

Tenderer(s) shall arrange to bring Interlocking Paver Block from approved plants registered with M.C.G.M., during the execution of the work. **The valid list of approved paver blocks manufacturers plants at “the time of execution of works” to be obtained from the Dy.Ch.Engineer (Roads)City office.**

The Municipal Site Engineer to ensure the validity of registration certificate of paver block plant and compliance of conditions laid down in the registration certificate issued to the paver block plant owner before receiving paver blocks.

- **List of approved R.M.C. Plants**

Tenderer(s) shall arrange to bring RMC mixes from approved plants registered with M.C.G.M., during the execution of the work. **The valid list of approved R.M.C. plants at “the time of execution of works” to be obtained from the Dy.Ch.Engineer (Rds)E.S.’s office.**

The Municipal Site Engineer to ensure the validity of registration certificate of RMC plant and compliance of conditions laid down in the registration certificate issued to the RMC plant owner before receiving RMC mixes.

- **LIST OF THE APPROVED MANUFACTURERS FOR SUPPLYING M-35 GRADE PRECAST KERB STONES AND WATER TABLES**

Sr. No.	Name & Address of the manufacturer	Location of RMC Plant/ Place of manufacturing
1.	M/s.Surface Road Constructions, D-30/004, Yogi Vaibhav CHS Ltd., Yogi Nagar, Eksar Road, Borivali (W), <u>MUMBAI – 400 091.</u> Ph.No.30903429/982127744	Plot No.472, Opp. Text Tube Factory, Nr. Garuda Petrol Pump, Charkop Industrial Estate, Kandivili (W), MUMBAI – 400 091.

2.	M/s. Unity Infraprojects Ltd. 1252, Pushpanjali Apartment, 1st floor, Old Prabhadevi Road, Prabhadevi, <u>MUMBAI-400025.</u>	MMRDA Plot, Phase IV, Wadala Truck Terminal, Wadala, MUMBAI - 400 034.
3.	M/s.Magnum Const. C-107, Shyamkamal, Agarwal Market, Tejpal Road,Vile Parle (East), <u>MUMBAI- 400 057.</u>	Behind Diamond Ind. Estate, Ahead of Dahisar Toll Naka, Ketkipada, Dahisar (E), MUMBAI-
4.	Relcon Infraprojects Pvt. Ltd., 105/C, Shyam Kamal, 1 st floor, Agarwal Market,Vile Parle (East), <u>MUMBAI- 400 057.</u>	BEST Plot, Kandarpada, Dahisar (W), Mumbai,
5.	M/s. Shree Constructions, 8/44, Vineet Nagar, Cotton Green, <u>MUMBAI- 400 033.</u>	Tembhode village, New Panvel, Dist. Raigad

Note : The valid list at the time of execution of works can be obtained from the Dy.Ch.Eng. (Roads) E.S.'s office.

• LIST OF THE APPROVED MANUFACTURERS FOR SUPPLYING M-25 GRADE PRECAST FRAME & COVERS AND M 35 GRADE DIVIDERS (CENTRE MEDIAN)

Sr. No.	Name & Address of the manufacturer	Location of RMC Plant/ Place of manufacturing
1.	Relcon Infraprojects Pvt. Ltd., 105/C, Shyam Kamal, 1 st floor, Agarwal Market, Vile Parle (East), <u>MUMBAI- 400 057.</u>	BEST Plot, Kandarpada, Dahisar (W), Mumbai,
2.	M/s.Shree Constructions, 8/44, Vineet Nagar, Cotton Green, <u>MUMBAI- 400 033.</u>	Tembhode village, New Panvel, Dist. Raigad

Note : The valid list at the time of execution of works can be obtained from the Dy.Ch.Eng. (Roads) E.S.'s office.

• LIST OF THE APPROVED MANUFACTURERS FOR SUPPLYING FRP / GRP FRAME & COVERS

Sr. No.	Name & Address of the manufacturer	Brand Name
1.	M/S Thermo Poly Products (I) Pvt Ltd, Ameza plaza, C-302, 3 rd floor, plot no-52, Sector 15, CBD belapur, New Mumbai — 400614.	Thermodrain
2.	M/S Titan Enterprises, 44, Khanna Construction House, East wing 2 nd floor, above flora Chinese restaurant, AGK road, Worali, MUMBAI-400018.	Everplast
3.	M/S Parshwanath Concrete, Shop No. 5, Shivom Co Op Hsg Soc, Opp Greater Bombay Co Op Bank, Ratan Nagar, Borivali (E), Mumbai.	Parshaw

Note : The validity of the list of approved manufacturers shall be confirmed from Dy.Ch.Eng. (SWD) PC.'s office at the time of execution of works.

Annexure –H

Rates of testing fees and quantity of samples for tests as approved

Sr. No.	Description of test	Reference Standard	Rate in Rs. per test	Quantity of sample required
A	AGGREGATES(COARSE & FINE)			
1	Sieve Analysis(dry)/ Fineness Modulus	IS 2386:Part I-1963 IS 383-1970, MORTH- 4th Revision, 2001	810	20 Kg.
2	Silt Content		1010.00	2 Kg.
3	Specific Gravity	IS 2386:Part III-1963	740	1 Kg.
4	Impact Test	IS 2386:Part IV- 1963, MORTH- 4th Revision 2001	1010.00	10 Kg.
5	Crushing Value/10% Fine Value		1200	10 Kg.
6	Los Angeles Abrasion Value		1780.00	10 Kg.
7	Water absorption	IS 2386:Part III- 1963 4th Revision 2001	740	1 Kg.
8	Flakiness Index	IS 2386:Part I- 1963 4 th Revision 2001	810	10 Kg.
9	Elongation Index		810	10 Kg.
10	Combined Flakiness & Elongation Index		1580.00	20 Kg.
B	ASPHALT			
11	a)Asphalt Macadam/ Bituminous Macadam, Asphalt Mixes (Extraction & gradation)	IRC 27-1967	1540.00	7 Kg. See Note-2
	b) Seal Coat (Extraction & Gradation)	Specification MORTH-2001	1540.00	3 Kg. See Note-2
12	Binder Course (Extraction Gradation Density, Voids)	Specification	2180.00	7 Kg. See Note-2
13	Asphalt Concrete/ Bituminous Concrete/ Dense Bituminous Concrete/Polymer Modified Binder (PMB)/ Crumb Rubber Modified Binder(CRMB) (Extraction, Gradation, Density, Voids, Flow Value, Marshall Stability.	IRC 29, MORTH 2001, IRC-SP-53- 1999	3160.00	7 Kg. See Note-2

14	Mastic Asphalt (Extraction, Gradation, Hardness No)	IS 5317-1987 IS 1195-1978	1970.00	2 specimen each of 10 cm dia or 10 cm square 2.5/thick cm.
15	Field density of Asphalt Mixes/Soil	IS 2720:Part 28 1974 (Reaffirmed 1995)	2180 for first test& 1120.00 each addl.Test.	.
16	Specific Gravity of bitumen	IS 1202-1978	1010.00	2 Kg. See Note-8
17	Penetration test of bitumen	IS 1203-1978	1010.00	2 Kg. See Note-8
18	Softening test of bitumen	IS 1205-1978	1260.00	2 Kg. See Note-8
19	Job Mix Formula for Asphaltic Mixes	Asphalt Institute Manual MS-2	19510.00	25 Kg.Coarseaggr eagate. 25 Kg.Fineaggre agate,10 kg filter,5 kg bitumen
20	Presence of Antistripping agent	CRRI Specifications	920.00	1 Kg bitumen from Plant (sealed)
21	Effectiveness of Antistripping agent		1540.00	1 Kg. in wide mouth bottle
22	Ductility test of bitumen	IS 1208-1978	1400.00	1 kg.in wide mouth bottle
23	Flash Point & Fire Point	ASTM	920.00	1 kg.in wide mouth bottle
24	Loss on heating, Thin Flim Oven Test	IS-1212	1540.00	1 kg.in wide mouth bottle
25	Elastic Recovery of half thread in Ductilometer at 15 ° C on PMB/CRMB	IRC:SP:53:2002	1540.00	1 kg.in wide mouth bottle
26	Viscosity Test	IS-1206-1978	1680.00	2 kg See Note- 8
C	SOILS			
27	Specific Gravity	IS 2720:Part 3-1980	920.00	1 Kg.
28	Bulk density		590.00	2 Kg.
32	Void ratio(Density & Sp. Gravity)		650.00	

29	Natural Moisture Content	IS 2720:Part-2 1973	460.00	2 Kg. See Note-9
	Permeability (Variable or Constant head)	IS 2720-: Part 17-1986	170	2 Kg.
30	Liquid Limit	IS 2720-: Part 17-1985	810.00	10 Kg.
31	Plastic Limit		810.00	
	Direct Shear Test	IS 2720: Part 13-1986	500	See Note-1
	Unconfined Compressive Strength	IS 2720: Part 10-1991	500	See Note-1
	Consolidation Test	IS 2720: Part 15-1980	600	See Note-10
33	Standard Proctor Test	IS 2720: Part 7-1980	2180.00	20 Kg.
34	Modified Proctor Test	IS 2720: Part-8 1980	2180.00	20 Kg.
Sr. No.	Description of test	Reference Standard	Rate in Rs.per test	Quantity of sample required
35	Laboratory C.B.R. Test	IS 2720: Part 16-1987	2690.00	25 Kg.
36	Dry Sieve Analysis	IS 2720: Part 15-1980	650.00	25 Kg.
	Wet Sieve Analysis		250	10 Kg.
37	Field C.B.R. Test	IS 2720:Part 31, 1990	2180.00 for first test and Rs.1120.00 for each addl.test	
38	S.B.C. of soil	----	2180.00 for first pit and Rs.1120.00 for each addl.pit	
D	BUILDING MATERIALS			
	CEMENT			
40	Cement (Initial & Final Setting time, Compressive Strength)	IS 269, IS 8112, IS 12269	2750.00	7 Kg. See Note-6
	Lime	IS 4031 (Part-III)-988	500.00	3 kg
	BRICKS			
42	(a) Bricks (Set of Ten) (Compression Test, Absorption Test)	IS 1077-1986	1970.00	10 Nos.
	STEEL			

43	Steel bars (6 mm dia to 20 mm dia) (Area on Weight basis, Yield Stress/0.02% Proof Stress, Ultimate Tensile Strength % Elongation)	IS 432-1986 IS-1786-1985	2040.00	60 cm. see Note 1 (c)7
44	Steel bars (above 20 mm dia) (Area on Weight basis, Yield Stress/0.02% Proof Stress, Ultimate Tensile Strength % Elongation)		2440.00	60 cm. see Note 1 (c)7
CONCRETE				
45	Concrete Cube (Compressive Strength)	IS 456-2000, IS 516-1959	920.00	3 Nos. See Note 1(c)
46	Concrete Beam (Flexure Test) (10x10x50 Cm)	IS 456-2000, IS 516-1959	1200.00	3 Nos. See Note 1(c)
47	Concrete Beam (Flexure Test) (15x15x70 Cm)		1200.00	3 Nos. See Note 1(c)
TILES				
48	Tiles (Absorption Test)	IS 41237 IS-13801-1985	1120.00	6 Nos. for each test
49	Tiles (Wet Transverse Strength Test)	IS-1237-1980 IS-13801-1993	1120.00	6 Nos. for each tes
50	Tiles (Abrasion Test)	IS 13630 Part-12-1993	2180.00	See Note No.14
WOOD				
51	Wood(Moisture content)	IS 287-1993 (Reaffirmed 1998) IS 11215-1991	920.00	See Note No.13
CORES				
52	C.C.Road Core (Compression Test)	IS 456-2000 IS11215-1991	4330.00 per core	----
R.C.C. COVERS				
53	R.C.C. Cover & Dhapa testing	IS 12592-Part-I 1998	920.00	
R.C.C. PIPES(Hume Pipes)				
54	a) Upto 600 mm dia.	IS 3597-1998 (Reaffirmed 2001), IS 458-1988	3840.00 per pipe	Minimum one pipe of each dia. Per lot

	b) 600 mm to 900 mm dia.		4330.00 per pipe	
	c) 900 mm and above		4910.00 per pipe	
CONCRETE PAVING BLOCKS				
55	Paver Blocks (As per Road Dept., requirement)			
	a) water absorption test	IS-15658-2006	1010.00	3 nos
	b) compressive test		1970.00	8 nos
	c) tensile splitting test		1970.00	8 nos
	d) abrasion test(dry test)		1970.00	See note no 19
56	SWD/MANHOLE FRAME AND COVERS(FRP COVERS			
	a) light/medium duty(failure load test	IS-1726-1991 reaffirmed 2007 and BS/EN-124-2004	1800.00	1 nos per lot of 50 covers
	b) Heavy duty(failure load test)		2690.00	
57	C.I FRAME AND COVERS			
	a) light/medium duty(failure load test	IS-1726-1991 reaffirmed 2007	1800.00	1 nos per lot of 50 covers
	b) Heavy duty(failure load test)		2690.00	
58	WATER TABLE (Failure load test)	BS-7263”part 1:1990	1800.00	1 sample for 1000 nos of product
59	KERB STONE(Failure load test		1800.00	
60	Welding test(tensile)	IS3600:1966	1340.00	See note 20
OTHER CHARGES				
	Duplicate additional copy of test report not older than 5 years		53.00 per copy	

Note: The aforesaid Testing charges are as per Circular issued by **Ch.E (Vig) U/no.Ch.E(Vig)/3898/B dtd21.03.2018**. The notes mentioned are as per circular. The rates may vary as per circular issued in this regard by Ch.E(Vig) of M.C.G.M. from time to time.

SECTION -15
SPECIAL CONDITIONS OF
CONTRACT

SPECIAL CONDITIONS OF CONTRACT

1. The Tenderer(s) shall note that this contract envisage following works in general:

a)	Construction/Re-Construction/Training/Widening of New Nalla/ Nallas as per the alignment shown in typical Drawing. However the same may vary in accordance with the site condition and as directed by the site-in-charge.
b)	Construction of Access road/pathway abutting to nalla if required.
c)	Construction / Remodeling of existing culverts if required
d)	Reconstruction of collapsed existing Nalla walls, etc.
e)	Contractor has to make arrangements for cofferdam wherever required since the site is affected by tidal effect for which no separate payment will be made.
f)	Contractor has to carry out the desilting of nalla and transportation of desilted material throughout the contract period.
g)	The trees affected in the alignment of Retaining Wall and Pathway shall be removed/ Transplanted by the contractor by obtaining permission from tree authority. The successful tenderer(s) has to deposit the requisite amount with Tree authority for faithful compliance of permission from Tree Authority.
h)	Contractor has to make arrangement for own dumping plot to dump desilted / excavated material at his own risk and cost
i)	Diversion of existing SWD flow if required shall be carried out by contractor on his own cost. No separate charges will be paid to the contractor.
j)	The Contractor shall maintain smooth flow of storm water in nalla/ S.W.D throughout contract period by way of desilting etc. as directed by Site Incharge.

2. The representative of the Engineer for this work will be from the offices of respective Dy. Chief Engineer (SWD).

3. Detailed plans will be available for inspection in the office of respective Deputy Chief Engineer (SWD).

4. The Tenderer(s) should simultaneously work at number of places or more and complete the work within contract period.

5. The contract period is including period required for mobilization, procurement of material, traffic permission, NOC from Land owning authorities for works, also other required

permission viz. erection of site office etc. and shall be reckoned from the date of issue of work order.

- 6.** The contractors will have to obtain permission from the land owner/Land owning authorities etc, well in advance before commencement of work through their premises for execution of the work by displaying appropriate boards. The work may be required to be executed in phases as per respective authority permission. The contractors should therefore take this factor into account while quoting.
- 7.** Programme of work: If at any stage the previously approved programme is required to be modified the contractors shall do so immediately as directed by the Engineer. If it is necessary to close some phase of the work and start a new phase as directed the tenderer(s) do so without claiming any extra payment. The programme shall be reviewed periodically and rescheduled as directed.
- 8.** All material required for the work can be stacked near the site of work in such manner so as not to cause any inconvenience to the pedestrian and vehicular traffic. If no space is available on site then tenderer(s) shall make his own arrangement for stacking of material etc. No extra payment will be made on this account.
- 9.** The Tenderer(s) shall maintain smooth flow of storm water in nalla/ S.W.D throughout contract period by way of desilting as directed by Engineer-in-charge for which no extra payment will be made.
- 10.** No extra payment shall be admissible for dewatering the trenches, carrying the material by head load transport or approaches to the work site.
- 11.** The contractors will have to obtain water connection for drinking purposes as per conditions in G.C.C. Extra water required for construction purposes will have to be brought by the contractors at his own cost and no extra claims on this behalf will be entertained.
- 12.** The Tenderer(s)/ Tenderer(s) shall note that first class quality of material & workmanship is expected.
- 13.** Quantities of all items provided in the B.O.Q. may not be required to be executed depending upon the site conditions. The tenderer(s) shall not be entitled for any compensation on this account. Before starting the work Tenderer(s) shall consult with the Site Engineer and shall take actual measurements on the site for procurement of material.
- 14.** The Tenderer(s) shall procure all material required for the work from manufacturers with (ISI) certificates and according to M.C.G.M. specifications wherever applicable. Tenderer(s) shall submit manufacture's test certificate accordingly.

- 15.** The contactors will have to work during nighttime also if required no extra claims in this regard will be entertained.
- 16.** For minor details of R.C.C. work and whenever any modification is desired same have to be done according to the R.C.C. code of the M.C.G.M./ I.S. code and as directed by the Engineer-in-Charge.
- 17.** Tenderer(s) should note that the measurements for the excavation items will not be taken for whole quantity of the excavation from the ground level up to the depth specified but will be taken for the quantity excavated between the specified depths only.
- 18.** The successful tenderer(s) will have to make his own arrangement at his cost for the Electric power supply required for the work either by taking connection from Reliance energy Ltd./ M.S.E.B. / B.E.S.T. / TATA or arrange his own generators.
- 19.** Tenderer(s) shall have to obtain all the permissions of the concerned authorities outside the M.C.G.M. required for carrying out the work. Only recommendatory letters will be issued by M.C.G.M.
 - a)** If required, the contractor shall appoint liaison officer for pursuing matters with the MMRDA, MCZMA, MRDPA, concerned Dy. Collector (Encroachment), concerned Municipal authorities, City Survey office, Reliance Energy, Tata power, Traffic Police or any other concerned offices for expediting encroachment / hurdles removal work from the alignment of Nalla system.
 - b)** Tenderer(s) shall have to obtain all the relevant permissions/ NOC from MCZMA, or any environmental and forest authority if the construction site falls under coastal Regulation zone or affected due to CRZ, the tenderer(s) has to get it done by approaching / liaison officer for pursuing the same .Only recommendation letters will be issued by the Corporation. The construction work affected due to CRZ will be allowed to be continued subject to clearance of environmental point of view.
- 20.** If due to small quantity of concrete (Less than 10 Cu.m.) or if concrete is not to be used as structural concrete nominal mix of equivalent strength may be made on site by the permission of Engineer, not below the Executive Engineer. However, rebate of Rs. 100/- per Cu. M. shall be taken for non-using the mix design.
- 21.** Contract Labour (Regulation and Abolition act 1970): The Tenderer(s) should specifically note that the successful tenderer(s) shall have to strictly comply with the entire statutory requirement under the provision of the Contract Labour (Regulation and Abolition) Act 1970 and with the Maharashtra State Contract Labour (Regulation and Abolition) Rules 1970 and

indemnify the Corporation against any claim(s) whatsoever. Successful Tenderer(s) should obtain Registration Certificate from Labour Commissioner.

- 22.** The Noise level shall be maintained within the permissible limit in silent zone area during construction activities by the Tenderer(s) as per the notification dated 14/01/2000 issued by the Ministry of Environment and Forests.(Condition is included as per circular u/no. C.E/PD/7788/I dated 07/11/2008).
- 23.** List of approved Banks/ Paver block manufacturers/ Asphalt Plants/ R.M.C. Plants etc. have been attached to this document. However, M.C.G.M. reserves right to modify these lists.
- a) All the asphalt works required to be done under the captioned contract shall be got executed with the specified asphalt mixes manufactured in M.C.G.M. approved asphalt plants only.
- b) All the Paver blocks/ Kerb stones/ Water tables/ Frame & covers required for the works to be carried out under the captioned contract shall be procured from the specified manufacturers registered with M.C.G.M. only.
- c) The R.M.C. works required to be done under the captioned contract shall be got executed with the specified R.M.C. mixes supplied by M.C.G.M. approved R.M.C. plants.
- d) The Mastic Asphalt work will be got done through the specialized agencies having expertise in Mastic Asphalt work.
- 24.** While constructing/improving footpath, provision for slopping ramp of at least 1.00 m width or as directed, shall be made at every carriage entrance, junctions, bus stops etc., for convenience of physically challenged persons.
- 25.** The full time services of the Personnel Team of the Tenderer(s) is mandatory during the entire period of the project.
- 26.** The site shall be cleared by removing all surplus material/silt/earth/debris on or before 31st May of every year.
- 27.** If the Tenderer(s) excavates certain portion of the road and fails to reinstate the same within the stipulated time limit, as per the programme and or before 31st of May, the reinstatement will be got carried out at contractor's risk and cost through other agency in addition to further penal action.
- 28.** All the excavated material belongs to the Municipal Corporation of Greater Mumbai and therefore shall be the property of Municipal Corporation of Greater Mumbai. It will be mandatory on the part of contractor to use this material in the execution of works under the instant contract or on any other sites of other contracts of M.C.G.M. as directed by the

Engineer; if the quality of material is as per the specification. If any excavated material is used on construction sites then the remainder surplus earth OR if no excavated material is utilized on Municipal works then the entire surplus excavated earth / material including de-silted material shall be removed / transported from sites by the contractor within 24 hours; for which no separate payment will be made. If Municipal dumping grounds are not available for removal of surplus earth then the contractors shall make his own arrangements for removal / transportation / disposal of excavated surplus earth at his own risk and cost. It shall be distinctly noted that M.C.G.M. will not make any payment towards removal / transportation / disposal of surplus excavated earth including desilted material from construction site to either any Municipal dumping ground (If made available) or to contractors own dumping facility. The contractors shall take into account the fact while quoting.

- 29.** The Tenderer(s) should note that during the execution of the work, debris etc, dumped on the public streets / places will have to be removed immediately after completion of the work as per direction of the Engineer failing which the same will be got removed at their risk and cost.
- 30.** The work will be treated as completed only after cleaning the site in all respect after completion of the work.
- 31.** Tenderer(s) should maintain the asphalt road stretches in traffic worthy/ motor able condition for the entire length mentioned in the scope of work including monsoon period also by attending potholes by using asphalt mixes up to the completion of contract period for which no extra payment will be payable may please be note.
- 32.** The contractors shall display the boards giving information of name of the work, date of starting completion, Name of the department and contact telephone numbers. Non-compliance of this condition, a penalty of Rs. 1000/- per day per site shall be imposed on contractor.
- 33.** The Tenderer(s) shall take photographs of site as and when directed by Engineer. The Photographs should be so arranged in the Register that original site position and finished site position of the same location should be vis-à-vis. The register should be duly signed by site-in-charge and Tenderer(s) fortnightly. Failure to abide this condition of Rs. 1000/- per photograph copy will be recovered from the contractor's bill.
- 34.** On Completion of the work, the contractors shall furnish free of cost 2 sets of final completion drawings in AutoCAD along with the soft copy in CD, showing all the details checked and signed by the Engineer within 2 months of completion of works. The payment

of final bill shall be made to the contractors after receipt of above sets. In case the contractors fail to submit the completion drawings, the same shall be got done through outside agency and cost of the same shall be recovered from the Tenderer(s) along with the penalty of Rs. 5,000/- per drawing (applicable for only identified works.)

- 35.** All trenches taken in connection with the work should be sufficiently barricaded, as specified. If barricading is not provided a penalty of Rs. 1000/- per day for every 10.0 m stretches will be imposed.
- 36.** Tenderer(s) should note since the work is to be completed expeditiously. The work should be in progress at several points along the length of the nalla. The Tenderer(s) should put in sufficient resources so as to ensure that the work is completed within the prescribed time period. Time is the essence of the contract. For this purpose, the tenderer(s) may be required to submit a PERT CHART showing the proposed schedule on which basis they intend to execute the work within the prescribed time period. The Tenderer(s) will have to submit BAR CHART, PERT Chart within 15 days from the issue of work order failing which a penalty of Rs. 2000/- per day will be imposed to the contractors.
- 37.** (a) The quantities mentioned in the Bill of Quantities have been worked out by adding the estimated quantities for each individual work mentioned in the tender document.
(b) Any excess or saving in any item will be considered on total quantities included in the Bill of Quantity of that item in the tender documents.
(c) Tenderer(s) will have to arrange for unforeseen diversion of utility services during execution at his risk and cost.
- 38.** The contractors should carry out if required any minor works pertaining to S.W.D. works, as may be decided by the Engineer-in-charge anywhere in the ward limit where the work is in progress under contract at the rates included in the Bill of Quantities of the above work with his percentage quoted.
- 39.** The payment for excavation shall be made on cross sectional basis. Before starting the work initial levels will be taken at every 5 m to 2 m or less depending on site conditions along the entire length of the proposed work levels at every 1.50 m to 2m minimum would be taken along the width of the section. The excavation quantity would be computed on the basis of levels thus taken by resorting the Prismoidal Formula or as directed by the Engineer-in-charge in case of encroachment and other structures. For establishing the datum line the average of the two end points of the ultimate cross-section required for excavation work will be considered.

- 40. Tenderer(s) should remove cofferdams constructed along/across the nalla before 15th May or as and when directed by engineer to keep the flow of storm water in the nalla unobstructed. No separate payment will be made for this.
- 41. The contractors are also required to reconstruct the cofferdam if required/directed by the Engineer to complete the balance work.
- 42. The proposed width for excavation of trenches for various sizes of pipes will be as shown in table at Condition No.6.5.2.
- 43. R.C.C. pipes to have used on site shall be as per specifications mentioned in the Tender and shall be procured from the Company Registered with M.C.G.M.

44. BARRICADING:

- It will be entirely responsibility of the contractor to provide and install secure barricades on work sites; **wholly at his risk and cost**. The specification and Drawing of the barricades is attached herewith as annexure – E and F.
- Installing secure and continuous barricading is to ensure the safety of the road users/residents of vicinity etc. Due to non-installation of barricades or due to inadequate installation of barricades on sites; if any accident occurs on site leading to injury or loss of life; then the contractors and contractor’s engineer will be liable for consequent action.
- Details of the work shall be prominently displayed in central panel of the barricades in following format

Name of work _____

Contract Cost _____

Date of starting _____

Time Period _____

Contractors Engineer Name _____

Mobile Number _____

- 45. No dumping ground will be made available by M.C.G.M. for disposal of desilted /excavated /surplus earth material from SWD. The tenderer(s) shall have to make their own arrangement for disposal of desilted / excavated / surplus earth materials. Please note that obtaining N.O.C. from Plot Owner for disposal of desilted / excavated / surplus earth materials on designated private dumping ground and dealing with all the consequences which may arise out of it’s utilization shall be the sole responsibility of the tenderer(s). All the

necessary charges including payment of Toll fees, Royalty (if any), etc shall have to be borne by the tenderer(s).

Any disputes / litigation regarding removal, transportation and dumping on site shall be sole responsibility of tenderer(s) and M.C.G.M. shall not be party for that in any case. Tenderer(s) shall indemnify M.C.G.M. and all its officers regarding any litigation and or issues that may arise out of ownership / NOC / Permission of said dumping site/s as well as removal / transportation / disposal of excavated surplus earth including desilted material. The indemnity bond stating the same shall be submitted in e-Packet B.

46. PENALTY CLAUSES :-

46.1 Penalties :

- a) The Engineer not below the rank of Assistant Engineer is entitled to impose a penalty of Rs. 2500/- per day for each defective work/lapse, disobedience of orders of the officer not below the rank of Site Engineer. Penalty amount will be recovered from contractors running bill.
- b) This penalty is over and above Penalty mentioned under G.C.C. clause No. 100.
- c) If it is observed that, the Tenderer(s) carrying out the work fails to comply with the instructions given by the authorities at the A.M.C./M.C.'s level during execution of work twice, the work will be terminated and will be carried out at the risk and cost of the Tenderer(s) and penal action will be taken against them. This decision will not be arbitrable at all.
- d) The abovementioned condition will be in addition to the provision of relevant condition in the General Condition of contract.

46.2 Penalties

- a) The stacked surplus excavated/desilted materials shall be removed immediately, failing which a penalty of Rs.5000/- per day per spot will be imposed.
- b) The dumpers carrying the surplus excavated material shall be covered with Tarpaulin sheets during transportation in accordance with MSW 2000 rules and no separate payment shall be made for the same. If the tarpaulin cover is not provided on vehicle or is torn out or small one, a penalty of Rs.5000/- per trip for that vehicle will be imposed.
- c) All the vehicles transporting surplus excavated material, earth, rock etc to dumping ground shall be provided with a board showing "On Municipal Duty". If the board

showing that the vehicle is “On Municipal Duty”, is not provided a penalty of Rs. **1000/-** will be imposed for per vehicle per trip.

- d) In the event of any delay on part of the Tenderer(s) to adhere to the contract, M.C.G.M. shall be entitled, at its option to recover from the Tenderer(s) as agreed, liquidated damages which shall not by way of a penalty but shall be a genuine pre-estimate of the losses that M.C.G.M. shall incur, a sum of 0.5% of the price of the total Contract Cost for each work or part thereof, by which the work has been delayed, subject however to a limit of 10% of the Total contract Cost, without prejudice to M.C.G.M.’s other rights mentioned in the Contract.
- e) The contractor shall have to take photographs. Failure to abide this condition , a Penalty of Rs. 1000/- per photograph copy will be recovered from the contractor’s bill
- f) Tenderer(s) are requested to take cognizance of the child labour act and to take precaution not to deploy child labourers on the work. If child labourers are found deployed on the work, a penalty of Rs. 5,000/- on the spot will be imposed on the defaulting contractor and further action as deemed fit will be taken.
- g) If the site office with the necessary requirements is not provided within 15 days from the receipt of work order, penalty of Rs. **2000/-** per day will be imposed.
- h) The contractors shall provide proper safety gears to their staff, labors. Failure to provide safety gears as per above clause a penalty of Rs. **1000/-** per labour per day shall be imposed. The contractor will be fully responsible towards the safety of staff and labor for the entire Contract period.
- i) If proper barricading is not provided by the contractor then a penalty of Rs. **2000/-** per meter per day will be imposed. Penalty on account of lapses in providing barricades will be cumulatively imposed to the tune of 5% of the contract cost
- j) Supply & Installation of liner shall start within **30** days from the approval of liner design failing which penalty of Rs. 10,000 per day per site shall be levied until start of installation of liners

47. If a registered Tenderer(s) (a firm, partnership or company) is deregistered, then any other registered Tenderer(s) (a firms partnership or company), with any partner or shareholder who is also a partner or shareholder or a “spouse” of such partner or shareholder of the deregistered Tenderer(s) shall also stand automatically deregistered.

48. Demotion shall be restricted to one class immediately below the existing class of registration, Demotion from the lowest class of registration will amount to deregistration.

- 49.** Demotion and deregistration shall apply to all the classes, categories and disciplines under which the Tenderer(s) is registered and will be valid for the remaining period of the contractors current period or registration or the period specified in the order of demotion, deregistration/ whichever is longer.
- 50.** A deregistered Tenderer(s) shall not be entitled to be issued any tender document / or quotations for any M.C.G.M. works. Such contractors shall also not be entitled to apply and be considered for renewal of registration or fresh registration at the expiry of period of deregistration. Similarly a demoted Tenderer(s) shall not be entitled to apply and be considered for renewal / fresh registration in a class higher than that to which he was demoted.
- 51.** Temporary huts for the labourer's huts for the S.W.Drains work may be permitted on work site in consultation with the respective Assistant Commissioners and subject to the following conditions or any other condition imposed by the Asstt. Commissioner.
- a)** The labourer's hutments will be completely isolated from the public by providing a tin sheet fencing around them.
 - b)** They will be specifically identified by M.C.G.M. staff by numbering them suitably.
 - c)** Adequate toilet and bathing facilities will be provided for them inside this fencing.
 - d)** The contractors will strictly observe that labourers will use these toilets and bathing facilities and no unhygienic conditions are created at site.
 - e)** In case, any of the above conditions is violated such hutments will be removed by the Assistant Commissioner without giving any notice to the Tenderer(s) in consultation with the Executive Engineer in charge of the work.
 - f)** The labourers hutments will be removed by the contractors within 7 days or the completion of the work or the last day of the month of May whichever is earlier.
- The Tenderer(s) has to check health of all the labours employed by him at every fortnight and take precautionary measures and treatments as per advice of medical officer. If record is not maintained, penalty of Rs.1000/- per labour will be imposed.
- 52.** Tenderer(s) shall note that no extra payment shall be made for carrying out filling / carrying out preparatory works like excavation, dewatering, compaction, access road, working platform etc. in / adjacent to nalla / river to facilitate implementation of piling works / construction of side walls and the quoted rates of tenderer(s) shall be deemed to include carrying out all temporary works etc. and removal of all temporary works after completion

of construction to the entire satisfaction of the Engineer-in-charge or before 15th May, whichever is earlier.

53. If the mangroves are required to be removed during execution of the work under the scope of the tender, the same shall be removed, as per directives of Hon.'ble High Court and as per prevailing Government Directions for which no extra payment shall be paid to the contractor.
54. The Bidder/Contractor has to appoint Structural consultant from M.C.G.M Registered / licensed Structural Engineer OR Renowned agencies like **I.I.T/ V.J.T.I./S.P.C.E.** for design and supervision of the works designed by them during execution the work and shall submit the **Structural Stability certificate** from the appointed consultant after completion of the work and before submission of the final bill. Tenderer shall take note of the same while quoting the bid.
55. The tenderer(s) shall carry out subsoil exploration / investigations at the site at his own cost wherever required and as per the directions of Site in-charge. Expenditure on this account will be deemed to have been considered in the rate quoted by the tenderer(s).
56. Any recommendation / alteration in the work as per decision of Competent Authority of M.C.G.M. shall have to be executed under the same tender conditions.
57. No claim shall be entertained on account of delay in removal of encroachment.
58. If the alignment of nalla retaining wall is affected by mangroves. The orders in cases pending in various courts in regard shall be binding on the contractors. The tenderer(s) cannot claim any damages / compensation etc. for delay or cancellation of the work or part thereof. This fact shall be kept in mind while quoting for tender.
59. It is observed that Contractors carrying out the work fail to comply with the instructions given by the A.M.C. /M.C. during execution of work twice, the work shall be deemed to have been terminated and will be carried out at the risk and cost of the Contractors and penal action will be taken against them. This decision shall not be arbitrable at all.
60. The above condition will be in addition to the relevant conditions in General Conditions of Contract regarding cancellation of full or part of the work, finality of the decisions on the disputes, differences or claims raised by the Contractors relating to any matter arising out of the contract.
61. If concrete surface Finish of work is not as per specified class of finish (i.e F1, F2, etc.) and honeycombing is observed in the surface, penalty of Rs. 5000/- per Sq.m. will be imposed.
62. Any recommendation / alteration in the work as per decision of Competent Authority of M.C.G.M. shall have to be executed under the same tender conditions.

- 63.** The Tenderer(s) shall implement anti-malarial measures for each site during execution of works in case of failure to implement above measures a penalty of Rs.5000/- per day per personnel shall be imposed.
- 64.** The contractors will have to obtain permission from the traffic police department well in advance either for closing down the road stretch or for diversion of traffic for execution of the work by displaying appropriate boards. The work may be required to be executed in phases as per traffic police permission. The contractors should therefore take this factor in to account while quoting.
- 65.** The guide wall of iron channels / brick masonry wall of sufficient section height shall be constructed to guide touch piles/meter panels for which no extra payment shall be made. If longitudinal alignment of the touch pile/meter panel differ more than 50 mm a penalty of Rs. 5000/- per meter depth of pile / meter panel will be imposed.
- 66.** The tenderer(s) should note that the work shall be carried out preferably during day time i.e. from 10.00 am to 05.00 pm only.
- 67.** If the structures/encroachments including utilities coming in the alignment of the proposed work, the contractor shall have to arrange for the carrying out detail total station survey of the structures/encroachments at his own risk and cost and the tenderer(s) have to quote accordingly while bidding for the work. No separate payment will be made.
- 68.** The contractors shall get the structures demolished from concerned Asst. Commissioner of ward for necessary working place to be made available for the subject work.
- 69.** Even though the Tenderer(s) takes all the precautionary measures and by chance any workman is injured or dies due to negligence or otherwise, the Tenderer(s) will be responsible for the claims of damages by the workman or his legal heirs.
- 70.** The Tenderer(s) has to check health of all the labourers employed by him at every fortnight and take precautionary measures and treatment as per the advice of Medical Officer. If record is not maintained by the Contractor, penalty of Rs. 1000/- per labour will be imposed.
- 71.** The design of R.C.C. / structural work shall be obtained from Licensed Structural Engineer at the cost of the Tenderer(s).
- 72.** Web Connectivity: The Tenderer(s) shall provide web connectivity to all above monitoring system. Web connectivity shall have minimum 1 MBPS Internet speed & 100% availability. Software should be intelligent. In case of connectivity failure it should maintain the pending files and send them as soon as it is connected. The Tenderer(s) shall make sure that the entire software and hardware solution is virus free.

- 73.**Quantities of all items provided in the B.O.Q. may not be required to be executed depending upon site conditions. M.C.G.M. reserves right to make any changes in scope of work / reduction of part or whole work. The tenderer shall not be entitled to claim any damages/compensation etc. for less quantity executed or cancellation of whole work or part thereof.
- 74.**The tenderer(s) shall note that during execution of work silt, excavated material, debris etc dumped on the public streets/places will have to be removed immediately as per direction of the Engineer-in-Charge, failing which the same will be got removed at their risk and cost.
- 75.**The contractors shall provide proper safety gears to their staff, labors. Failure to provide safety gears as per above clause a penalty of Rs.**1000/-** per labour per day shall be imposed. The Tenderer(s) will be fully responsible towards the safety of staff and labors for the entire Contract period.
- 76.**Boards of size 4' x 3' showing all the necessary details should be displayed at each and every nalla site. For non-compliance of this condition, penalty of Rs.**1000/-** per day per site will be imposed on the contractors.
- 77.**Tenderer(s) shall note building & other building worker welfare Cess @ 1% of construction cost as per Maharashtra State building & other building welfare Cess act 1996 will be deducted from contractor's bill as per act.
- a) Tenderer(s) should note that, there are only few access points in each Proposed work of this tender from where Machinery can be lowered for desilting work/ concreting work.
 - b) Tenderer(s) should note that, for inaccessible portion of proposed work of this tender the same shall be desilted manually by engaging adequate labour force and desilted material shall be conveyed up to loading point by head load.
 - c) If the contractor engages any machinery for collecting, carrying for lifting the silt from the Proposed work of this nalla system bed and if any damage appears to the nalla system bed or Retaining walls or any structure belongings to anybody due to impact of machines or due to any reasons the contractors will have to make good or such damages without any extra cost to M.C.G.M.
- 78.**Since the work under reference is time bound the work will have to be carried out beyond the normal specified working hours. (10.00 am to 5.00 pm) the tenderer(s) should make specific provisions for this contingency.

- 79.** The successful tenderer(s) shall provide lorries/dumpers & machineries as per prevailing norms of Mumbai RTO dept.
- 80.** All the necessary precautions, safety measures etc. for the contractors staff at the work site shall be the responsibility of the successful tenderer(s). The successful tenderer(s) shall also be liable for any injury to the life & damage to private, municipal or government properties if any caused by them during the operations connected with this work. In this if any legal issues arise in any term the contractors will be solely responsible for such kind of legal issues/disputes and M.C.G.M. will not be a party in this matter.
- 81.** All the tenderer(s) are advised to visit the site of work so as to ascertain the scope of work required for effective execution of work & also to ascertain difficulties of accesses/approach road, traffic restrictions on account of tidal conditions etc.
- 82.** The tenderer(s) shall take utmost care while transporting the wet silt/earth to dumping ground. The wet silt shall be transported in water tight vehicles to ensure that wet silt does not spill on the road and cause any accident in case of any such accident it will be the entire responsibility of the contractors to bear all the damage, claims, any untoward incidents if happened.
- 83.** The contractor shall make proper arrangement of lighting / focus during night hours at his risk and cost at site.
- 84.** The wood generated from tree cutting shall be deposited in the store of concern ward Horticulture Assistant / JTO & take acknowledgement for the same.
- 85.** The contractors shall carryout tree cutting / transplantation / work in consultation with ward Horticulture Assistant / JTO & obtain necessary completion certificate for the same.
- 86.** The silt must be transported within 48 hours to the specified dumping ground. However, in case of main roads, the silt will be transported by deploying vehicles immediately. The said vehicles shall be water tight. The wet silt shall not be allowed to drip out on the road during transportation.
- 87.** Tenderer(s) are hereby directed to take out C.A.R. (Contractors All Risk) Policy and W.C. Policies as directed under Clause No. 5y and 9c of the General Conditions of Contract 2016 for civil works.
- 88.** The tenderer(s) shall carry out the entrusted work as per BOQ and specification meticulously.
- 89.** The successful tenderer(s) shall take jointly the bed / bank / service road initial levels at every 5.0 mt distance for the starting point of group allotted to the tenderer(s) before

starting the work and submit the cross section as well as longitudinal section as per the directions of the Engineer In-charge free of cost. After completion of widening, deepening, cutting work again the successful tenderer(s) shall take jointly the bed / bank / service road final levels at every 5.0 mt. distance from the starting point of group allotted to the tenderer(s) and submit the cross section as well as longitudinal section as per the directions of the engineer In-charge free cost. The successful tenderer(s) shall provide necessary survey instruments for the survey work free of cost.

- 90.** No separate payment for any kind of transportation from site will be made for the work. Tenderer(s) should take cognizance of the same while quoting the bid.
- 91.** The royalties, taxes, charges, etc. for excavated material i.e. earth, rock, etc. will be borne by the contractors. As per revised policy of M.C.G.M., in case of municipal dumping, Contractors will be charged for tipping excess earth / material @ the rate of prevailing charges during execution of work. However, tipping charges including weighing the same shall have to be borne by the tenderer(s) for which no payment / reimbursement will be made. Considering these charges, tenderer(s) shall quote their percentage accordingly.
- 92.** All the directives regarding new policy for governing extra/ excess as per circular no. CA/F/Project/31 dated 26.10.2020, shall be followed.
- 93.** Responsibility of observance of terms & conditions of the contract and authenticity of inputs given and documents submitted shall be solely of the contractors. The staff / engineers shall not be held responsible for any lapse / mischief that may be observed during the course of execution.
- 94.** It is proposed to allow the tenderer(s) maximum upto 2 (two) private plots for dumping / unloading the desilted material/silt as per the work proposed.
- 95.** For transportation of excavated material no vehicular tracking system will be insisted since the item of transportation will not be paid.
- 96.** The tenderer(s) quoting/bidding for more than one work with respect to e-tender notice and intends to pay A.S.D. as specified in the tender then the tenderer(s) shall pay separate A.S.D. for each bid offline before end date and time of bid submission. In case the A.S.D. submitted is more than the percentage quoted by the bidder, then the percentage quoted shall prevail.

97. If the tenderer(s) is lowest in more than one bid, independently qualifies the PQ criteria of corresponding bid where he is lowest and has sufficient bid capacity to bid then in such cases more than one tender can be awarded to such bidder.

98. **For the purpose of working out current level of values for turnover, following multiplying factor shall be used:-**

Sr.	Financial Year	Multiplying factor
1	2020-21	1.10
2	2019-20	1.21
3	2018-19	1.33
4	2017-18	1.46
5	2016-17	1.61

99. One Tender per Tenderer(s) – Each tenderer(s) shall submit online only one tender for one work. Tenderer(s) who submits more than one bid for one work, individually will cause all the proposals with the tenderer(s) participation to be disqualified.

a) Firms with common proprietors/ partners connected with one another either financially or as principal agent or as master and servant or with proprietor/partners closely related with each other such as minor son/daughter and minor brother/sister shall not tender separately under different names for the same contract.

b) If it is found that firms described vide above clause have tendered separately under different names for the same contract, all such tenders shall stand rejected and tender deposits shall be forfeited. Any contract entered into under such conditions will also be liable to be cancelled at any time during its currency and penal action including black listing of such firms will be taken.

100. Cost of Tendering-

The tenderer(s) shall bear all costs associated with the preparation, submission and uploading of his Tender, and the M.C.G.M. will in no case be responsible and liable for those costs.

101. **Work Records:** - All specified up to date site record should be maintained by the contractors. If the Tenderer(s) fails to comply with this condition, the penalty of Rs.1000/- per day per record will be imposed on the contractors.

List of Registers

Sr. No.	Name of Register
1.	Inventory Register
2.	Correspondence file
3.	External & internal utility remarks file
4.	File containing drawings
5.	Daily Progress Register
6.	Instruction Register
7.	Level Book
8.	Mix design file
9.	Materials Testing Result file
10.	Photograph file
11.	Excavation Register (Asphalt , rock, soil etc)
12.	Filling/Embankment Register
13.	Granular Sub-base / K.T.R.Register
14.	Wet mix Macadam ./ Water Bound Macadam .Register
15.	Sand Metal Filling Register
16.	Misc work register
17.	M 15 CC Register
18.	M 20 CC Register
19.	M 40 CC Register
20.	M15,M20, M35/M40 Cube & Beam registers
21.	Ready Mix Concrete Challan file
22.	Cement Variation Register
23.	Cement Register
24.	Asphalt macadam (mixes) register
25.	Dense Bituminous Macadam Register
26.	Asphalt concrete /Seal coat Register
27.	Asphalt challan file
28.	Penalty Register.
29.	Steel register
30.	Visual/ video recordings in form of CD's
31.	Form work shuttering register
32.	Precast register
33.	Any other register as per directions of Engineer in Charge.
NOTE :	From above list the registers applicable for the specified work shall be maintained.

102. Minimum 2 security guards round the clock shall be provided on every worksite. A penalty of Rs 500/- per security guard per shift will be levied if the same is not provided.

103. Pre-bid meeting – (Applicable for tenders costing above Rs.25 Crores) :-

- a) The tenderer(s) or his authorized representative is invited to attend a pre-bid meeting as per the date, time and venue mentioned in the tender notice/Bid Information Sheet.
- b) The purpose of the meeting will be to clarify issues and to answer questions on any matter that may be raised at that stage.
- c) Any tenderer(s) requiring any clarification of the tender document and/or the works may submit his questions in writing to reach the office of Ch.E.(SWD) at least 2 days before the meeting.
- d) The text of the questions raised (without identifying the source of enquiry) and the response given will be circulated/informed vide addendum on <http://portal.mcgm.gov.in> portal displayed within 7 days. Any modification of the tendering documents, which may become necessary as a result of the pre-bid meeting, shall be made by the M.C.G.M. exclusively through the issue of an Addendum and not through the minutes of the pre-bid meeting.
- e) Non-attendance at the pre-bid meeting will not be a cause for disqualification of tenderer(s).

104. Any bidder or prospective bidder shall refer 'Internal Grievance Redressal Mechanism' as per circular no. DMC/CPD/3217/dtd. 02.03.2019 for redressal of their grievances.

MUNICIPAL CORPORATION OF GREATER MUMBAI

Central Purchase Department:

CIRCULAR

No. D.M.C./CPD/3217 Date: 02.03.2019

Sub : To incorporate new clause of Internal "GRIEVANCE REDRESSAL MECHANISM" in the standard Bid document.

Ref: i) CA/FRD/I/05 dt. 10.05.2016
ii) MGC/F/8155 dtd. 30.01.2019.

- Vide above reference, Hon'ble M.C. has granted to discontinue the existing Procurement Redressal Committee & to incorporate new clause of internal "GRIEVANCE REDRESSAL MECHANISM" as mentioned below in the bid document.

INTERNAL GRIEVANCE REDRESSAL MECHANISM

M.C.G.M. has formed a Internal Grievance Redressal Mechanism for redressal of bidder's grievances. Any Bidder or prospective Bidder aggrieved by any decision, action or omission of the procuring entity being contrary to the provisions of the tender or any rules or guidelines issued therein, in Packet 'A', 'B' & 'C' can make an application for review of decision of responsiveness in Packet 'A', 'B' & 'C' within a period of 7 days or any such other period, as may be specified in the Bid document.

While making such an application to procuring entity for review, aggrieved bidders or prospective bidders shall clearly specify the ground or grounds in respect of which he feels aggrieved.

Provided that after declaration of a bidder as a successful in Packet 'A' (General Requirements), an application for review may be filed only by a bidder who has participated in procurement proceedings and after declaration of successful bidder in Packet 'B' (Technical Bid), an application for review may be filed only by successful bidders of Packet 'A'. Provided further that, an application for review of the financial bid can be submitted, by the bidder whose technical bid is found to be acceptable / responsive.

Upon receipt of such application for review, M.C.G.M. may decide whether the bid process is required to be suspended pending disposal of such review. The M.C.G.M. after examining the application and the documents available to him, give such reliefs as

may be considered appropriate and communicate its decision to the Applicant and required to other bidders or prospective bidders, as the case may be.

M.C.G.M. shall deal and dispose off such application as expeditiously as possible and in any case within 10 days from the date of receipt of such application or such other period as may be specified in pre-qualification document, bidder registration document or bid documents, as the case may be.

Where M.C.G.M. fails to dispose off the application within the specified period or if the bidder or prospective bidder feels aggrieved by the decision of the procuring entity, such bidder or prospective bidder may file an application for redressal before the 'Internal Procurement Redressal Committee' within 7 days of the expiry of the allowed time or of the date of receipt of the decision, as the case may be. Every such application for internal redressal before Redressal Committee shall be accompanied by fee of Rs.25,000/- and fee shall be paid in the form of D.D. in favour of M.C.G.M.

1st Appeal by the bidder against the decision of C.E./HoD/Dean can be made to concerned D.M.C / Director who should decide appeal in 7 days.

If not satisfied, 2nd Appeal by the bidder can be made to concerned A.M.C for decision.

Grievance Redressal Committee (GRC) is headed by concerned D.M.C / Director of particular department for the first appeal / grievances by the bidder against the decision for responsiveness / non-responsiveness in Packet 'A', Packet 'B' or Packet 'C', and if not satisfied, concerned A.M.C. will take decision as per second appeal made by the bidder.

This Grievance Redressal Committee (GRC) will be operated through DMC(CPD) office where appeals of aggrieved bidder will be received with fee of Rs. 25,000/- from aggrieved bidder. The necessary correspondence in respect of said applications to the aggrieved bidder & concerned department, issuing notices, arranging of Grievance Redressal Committee (GRC) with D.M.C and further proceeding will be carried out through registrar appointed by MCGM.

No application shall be maintainable before the redressal Committee in regard of any decision of the M.C.G.M. relating to following issues:

Determination of need of procurement

The decision of whether or not to enter into negotiations.

Cancellation of a procurement process for certain reasons.

On receipt of recommendation of the Committee, It will be communicated his decision thereon to the Applicant within 10 days or such further time not exceeding 20 days, as may be considered necessary from the date of receipt of the recommendation and in case of non-acceptance of any recommendation, the reason of such non-acceptance shall also be mentioned in such communication.

Additional Municipal Commissioner and/or Grievance Redressal Committee, if found, come to the conclusion that any such complaint or review is of vexatious, frivolous or malicious nature and submitted with the intention of delaying or defeating any procurement or causing loss to the procuring entity or any other bidder, then such complainant shall be punished with fine, which may extend to Five Lac rupees or ten percent of the value of the procurement, whichever is higher.

- All head of department are therefore requested to take a note of above and process tenders accordingly.

Sd/- 21.02.19
D.M.C(CPD)

CIRCULAR

2018-19

No. D.M.C./CPD/3217 Date: 02.03.2019

CC: to

Director(E.S&P)	D.M.C(E)	D.M.C(S.E)	D.M.C(SWM)	D.M.C(Education)
D.M.C(Vig.)	D.M.C(Z-I)	D.M.C(Z-II)	D.M.C(Z-III)	D.M.C(Z-IV)
D.M.C(Z-V)	D.M.C(Z-VI)	D.M.C(Z-VII)	D.M.C(A&C)	D.M.C(Improvement)
D.M.C(D.M)	D.M.C(Spl.)	D.M.C(M.C's Office)	D.M.C(E.R.)	Director(M.E & M.I)
Ch.M.S(Sp. Hosp.)	E.N.O Dean (LTMG Hosp. & Med. College)	P.S. to M.C. Dean (B.Y.L Nair Hosp.)	C.E. Dean (Nair Hosp. Dental College)	P.S. to AMC(P) / as per / etc
Dean (KEM Hosp.)				H.E.
Ch.E.(D.P)	Ch.E.(Roads & Traffic)	Ch.E.(M.S.D.P)	Ch.E.(SWD)	Ch.E.(S.O)
Ch.E.(S.P)	Ch.E.(W.S.P)	Ch.E.(Vig.)	Ch.E.(B.M)	Ch.E.(S.W.M)
Ch.E.(Bridge)	Ch.E.(M&E)	Ch.E.(C.T.I. & R.C)	Ch. LO	Edu. Officer
M.A	Security Officer	Law Officer	Supt. Of Garden	Supt. Of Licence
M.C.A	M.S.	C.A.(E)	C.A.(T)	C.A.(W.S.S.D)

Copy submitted for information please

Dy. CA (Exp)

11/9/19 02/03/19
DY Ch.E.(CPD)

लेखा अधिकारी (प्रबन्ध) शि
3-11-19

Scanned by CamScanner

105. Information regarding Classes –

Classes classified in M.C.G.M with limits of works, standing Deposit, amount of solvency prescribed for each class as per New Registration Rules:-

Class	Upper Limit of Tending (Rs.in Lakhs)	Minimum Solvency (Rs.in Lakhs)
I(A)	Without Limit	150
I(B)	2500	150
I(C)	1500	150
II	750	75
III	300	30
IV	150	15
IV(A)	90	09
V	50	05
V(A)	30	03
VI	15	02
VII	10	01
VIII	5	0.5
IX	3	0.25

106. A responsive tender is one, which confirms to all the terms, conditions and specifications of the tendering documents, without material deviation or reservation a material deviation or reservation is one-

- a) Which affects in any way the scope, quality or Performance of the work.
- b) which limits in any way, the employer's rights or the tenderer(s) obligation under the contract and inconsistent with tendering documents.
- c) Whose rectification would affect unfairly the competitive position of other tenderer(s) presenting responsive tenders.

107. Dumping Grounds– Mention of the Municipal dumping sites in tender document does not cast any responsibility upon M.C.G.M. to make the same available to successful bidder. It all depends on availability of the dumping grounds. M.C.G.M. does not claim to make the Municipal dumping sites available to the successful contractor.

- a) The dumping sites may change at the discretion of Engineer at short notice, without any financial liability on M.C.G.M.

b) M.C.G.M. does not assume any responsibility for providing sites for dumping ground for removal and transportation of surplus excavated earth including de-silted material. In the event of Municipal dumping ground not available; the successful bidder shall have to make his own suitable arrangements for disposal of excavated surplus earth/ material / desilted material at his own risk and cost.

c) “M.C.G.M. will not make any payment towards transportation/ removal/ disposal of excavated surplus earth/ material / desilted material from construction site to either Municipal dumping ground (if available) or contractors own dumping facility. Contractors shall quote accordingly”.

d) Nevertheless, M.C.G.M. reserves its rights to use surplus excavated materials for its own use anywhere in M.C.G.M. limits and the contractor will have to dump the material at any sites as decided and directed by the engineer in charge; no extra payment will be made on this account.

108. If the site is affected due to Tidal effect and to facilitate construction activity Cofferdams will have to be constructed by the tenderer(s) and also tenderer(s) have to construct temporary road, F.O.B, etc while constructing the Nalla for which no extra payment will be made. Tenderer(s) need to consider this aspect at the time of quoting the Bid.

109. Above all any new guidelines or changes in existing system regarding keeping a check on the transportation of vehicles to private dumping ground will be binding on contractors and no extra payment what so ever will be made to the tenderer(s) in lieu any changes made or fresh guidelines issued.

110. It is required to prepare drawings/soil investigations /Total Station Survey drawings/Structural drawing and design, of the nalla retaining wall/ RCC work as per the site conditions or as directed by Engineer –in –charge. Contractors shall have to appoint Licensed Surveyor/Soil Investigation Consultant/RCC design Consultant at this own cost to prepare the drawings/soil investigation reports/Total Station Survey drawings/ RCC structural drawings and designs based on tender item conditions and get the design approval from the department of MCGM. The expenditure on this account will be deemed to have been considered in the rates quoted by the tenderer and no extra payment shall be paid to the contractor.

111. Tenderers shall have to follow the New Guidelines & Modalities for execution of Engineering Works circulated by Ch.E.(Vigilance) department u/no.Ch.E/Vig

/1581/B dated 21.09.2016.& u/no.Ch.E/Vig /1490/B dated 02.08.2018 and u/no. Ch.E. / Vig / 1938 / 8 dt. 23/11/2021.

- 112.** Methodology of the work, safety manual and quality assurance plan shall be submitted before commencement of the work with copy at each site office.
- 113.** Concrete Works:
All concrete works shall be carried out as per item description or by Ready Mix Concrete only.
- 114.** The work should be started from downstream and shall be handed over and commissioned in part as per the progress of the works. DLP of the part handed over SWD/ sewer line will be counted from the date of handing over.
- 115.** Diameter of the pipe and sizes of manholes provided in the bill of Quantities of the Tenders are tentative and are likely to change at the time of execution according to the site conditions. Contractors shall have to carry out such extra items in Sewer Line/Water mains works as per respective Schedule rates of M.C.G.M. prevailing at the time of execution of work adjusted by rebate/premium quoted by the contractors and no fair rate will be admissible for the same.
- 116.**
- a) The Mix Design for Concrete shall invariably include details of source material including tests carried out at source (Quarry/Cement Manufacturer's lab).
 - b) The contractors should carry out if required, any minor works such as raising/lowering of manhole, attending to bad spots, bad patches etc. as may be decided by the Engineer-in charge anywhere within the concerned ward limit where the work is in progress under contract at the rates included in the Bill of Quantities of the above work with his percentage quoted.
- 117.**
- i) All the specifications laid down by IRC and as detailed in the relevant clauses of MORTH- (2001) Manual on Specifications for Road and Bridge Works in respect of Construction of Drainage Layer, Wet Mix Macadam, Dry Lean Concrete should be strictly followed.
 - ii) All the works for thin/ ultra-thin white topping shall be carried out as per IRC – SP - 76.
- 118.** It will be the responsibility of the contractors to arrange for a joint inspection in every quarter of the year after completion of the work till the expiry of defect liability period and also 4 weeks before expiry of the defect liability period. Further, if the contractor fails to

do so, the observations made by the staff during site inspection will be considered for the purpose of noting the defects.

- 119.** (i) All the works shall be started from existing manhole at the downstream end of the proposed work so that the line laid will be put to use immediately.
- (ii) All the existing street connections / cross sewer lines shall be transferred to the proposed/existing sewer line, if any.
- (iii) The work may involves laying of augmentation of storm water line on narrow Gaothan street having existing utility such as Sewers, Water mains. At some location, proposed storm work will required to be carried out by dismantling existing sewer line and redo the same. It is likely that the new storm water line will be laid on existing alignment by isolating the same. The bidder has to desilt the existing storm water drain wherever required at their own cost.
- (iv) Before redoing of culvert work, the design of R.C.C./ Structural work shall be obtained from licensed Structural Engineer at the cost of tenderer.
- 120.** The Contractors may be called upon to execute additional work of laying small portion of storm water line/ sewer line in the vicinity of the present work under the proposed Contract. This fact should be taken into consideration while quoting the percentages or rates for the tender of the work.
- 121.** The contractor which expression shall include any person or group of person's representing the contractor who are required to handle iron and steel materials shall register themselves as employer with the Mumbai Iron and Steel Labour board and shall completely fulfill all the obligatory provisions of the Maharashtra Mathadi, Hamal other Manual Workers (Regulation of employment and Welfare) Act 1969, and the Mumbai Iron and Steel Unprotected Workers (Regulation of employment and Welfare) Scheme 1970. The consequences of failure of compliance of any of these provisions will entirely be the liability and responsibility of the Contractors.
- 122.** Any amount of Dewatering required for crossing nalla/culvert/S. W. drains, crossing of sewer lines etc. and also for making connection of the proposed SWD/sewer lines to the existing sewer line in surcharge conditions should be done free of cost. No payment will be made on that account. Contractor shall note the same and quote accordingly.
- 123.** The item of the constructing body manhole over functioning / nonfunctioning SWD/sewer of any diameter will be paid in regular manhole item which includes the cost

of breaking of concrete and pipe, desilting of SWD/sewer line, dewatering of SWD/sewer line, etc. The contractor should quote their rates accordingly.

- 124.** The contractors will have to make connections to the existing manhole including plugging, diverting or pumping the existing flow or accumulated water, making holes of any size in the masonry, breaking the existing cement concrete haunches, making sand plaster, constructing new channels and haunches with M 15 C. C. finished smooth with 20 mm. (3/4") thick cement mortar 1:1, de-plugging and desilting the manhole on upstream side and downstream including passing disc in the length complete as directed (for this item no payment will be given to the contractors).
- 125.** Where the excavation is required to be done across the road or along the part of a road where there is high volume of traffic, the Engineer may direct the contractor, to execute the work in more than one shift, so as to complete the work, in least required time, so as to reduce the inconvenience caused to the free flow of traffic. Arrangement will have to be made by the contractor to provide additional lights, sign boards etc. as required by the Engineer and traffic police. The contractor will have to provide M.S. plates of sufficient thickness, including stiffer plates for strengthening with supporting joints, if required, to cover the open trenches during the day time for smooth flow of traffic during the progress of the work and till the trench is backfilled. No extra payment will be made for this arrangement. The program of the work to be done in additional shifts shall be submitted to the Engineer and got approved before starting the work, so that the work can be completed in a time bound manner.
- 126.** It should be clearly understood that for the purpose of determination of the contract period, the monsoon period will be taken only as from 10th June to 30th September, and all works shall be recommenced on 1st of October, irrespective of whether there are intervening festivals and/or rains etc.
- 127.** Contractor will make arrangement to inspect R.C. pipe / H.D.P.E. pipe manufacturer's site to carry out three edge bearing tests, water tightness test.
- 128.** No material will be supplied by M.C.G.M. Stores.
- 129.** The per cent above or below quoted in this schedule shall hold good for all works done under this contract without reference to location of works or quantities.
- 130.** The contractors are particularly directed to observe from the specifications what is to be included in the rates for the several portions of the works and frame all their per cent above or below accordingly.

- 131.** It is incumbent on the Contractors to remove all “Pardis” put up by them during the progress of storm water work so as to obviate the necessity of such removal after the storm water is put into commission while handing over charge of such storm water line to the respective Department. If any such “Pardi” is found after the Storm water line is put into commission the cost of breaking and removing the same will be recovered from the Contractors.
- 132.** After completing the work, completion plan shall be sent to the Dy. Chief Engineer (SWD) City & after verification & acceptance, the whole of the work should be handed over to E.E. (O&M) SWD (Mech.) of the respective zone for maintenance. A copy of the memo acknowledging the taking over of the work should be handed over to the Ex-Engineer in charge of the work.
- 133.** In respect of Filling in trenches with Municipal earth materials etc. in layers not exceeding 25cm. in loose thickness, watering etc. compacting by means of plate vibrator or a power roller to a depth not exceeding 2m. etc. complete as per New Road Specifications / trench guidelines effective from 01.02.2015.
- 134.** Scope of Work includes minor changes in alignment due to site difficulties, if arises. Contractors are liable to carry out the SWD/sewer work as instructed by the Engineer of Contract.
- 135.** Tenderer shall have to provide an air-conditioned site office admeasuring about 20 sq.m. (Minimum) with at least two windows and with all the security kits and safety measures for labourers shall be provided by the tenderers along with the conditions mentioned in Clause no.68.5 and 68.6 of GCC of this document. Also Digital camera with minimum 16 Mega Pixel lenses shall be provided for the tendered work.
- Note:** As number of site locations in this work are 22 nos. at different locations in City area, Tenderer has to provide 5 (five) nos. of site offices during execution of work and 2 (two) nos. of site offices during five (5) year comprehensive maintenance period for this work, as directed by Engineer-in-charge.
- 136.** For Barricading at the site should be free of cost (No payment will be made) by the Contractor and strictly follow Circular no. U/No.MGC/F/6342 dated 5.5.2018.
- 137.** Scope of Work includes minor changes in alignment due to site difficulties, if arises. Contractors are liable to carry out the SWD/sewer work as instructed by the Engineer of Contract.

- 138.** On receipt of the work order, an amount equivalent to 1/2% (half percent) of Contract cost or Rs10,000/-, whichever is less, shall have to be deposited on demand by Ward Office where the work site is situated, towards deposit for removal of debris from the site. This amount will be adjusted towards the debris which has not been removed from the site by the contractors in time and removed by the Ward Staff.
- 139.** For “Time extension of work”, strictly follow Circular No. AMC/ES/ 2700, dated 27/05/2019. Accordingly, Bidder shall submit the undertaking by mentioning that the subject work will be completed in stipulated time period and in case of not completing the work within stipulated time period, penalty will be recovered for such lapses as per tender condition.
- 140.** As per circular MGC/F/7076 dt 30/08/18 It is directed to dispose of construction and demolition waste material by following due procedure in accordance with the provision of the Construction and Demolition Waste Management Rules-2016.

Digital Signature of Tenderer(s)

SECTION – 16
TYPICAL DRAWINGS

Name of Work: CT-60 work of construction of RCC box drain of size 4m x 2m along Sion-Mahim link road from piwala Bunglow up to T-Junction in G/N ward.

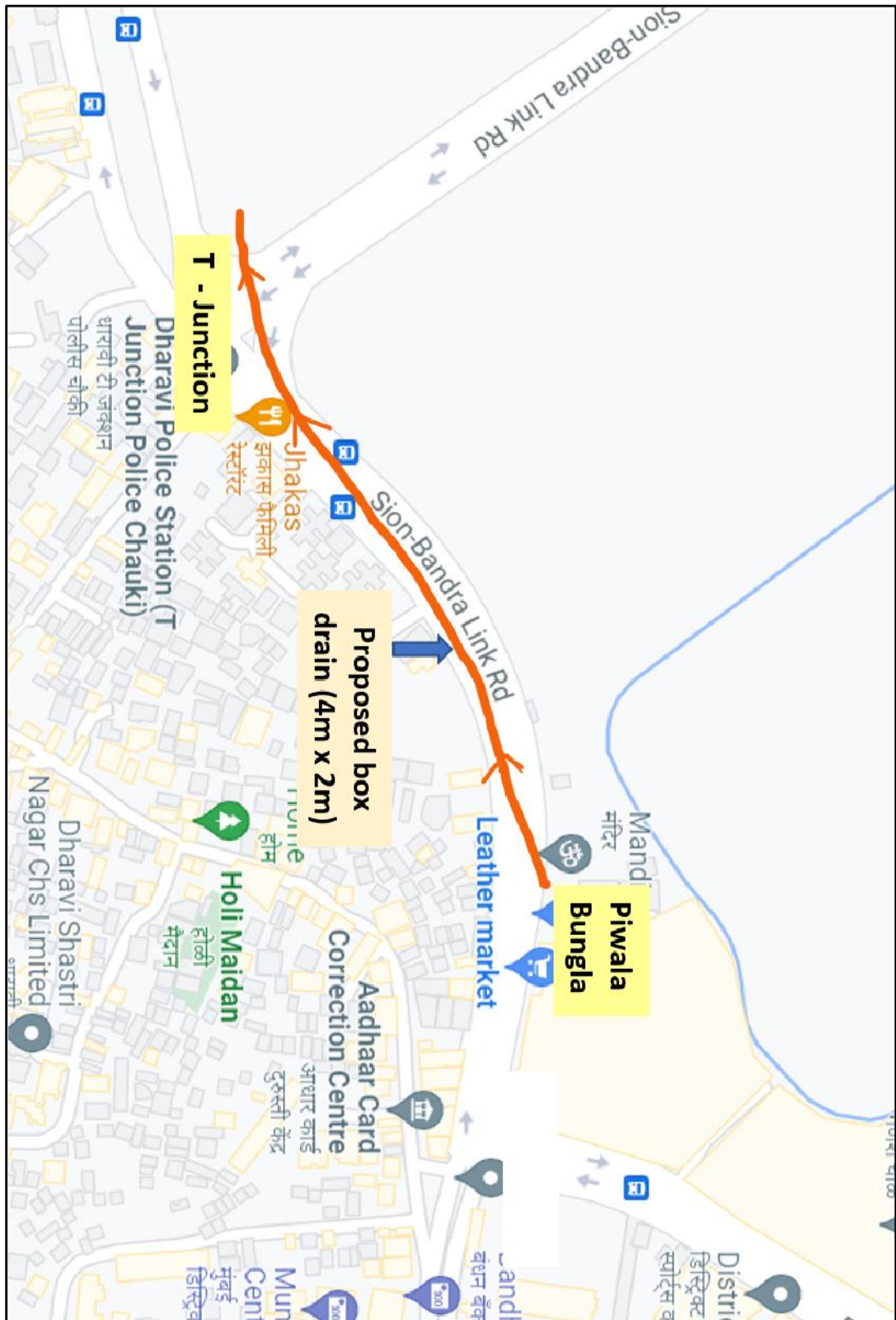

SECTION – 17
FINANCIAL BID FORM
(FORM ‘B’)

Financial Bid Form 'B'

Sub: e-Tender - CT-60 work of construction of RCC box drain of size 4m x 2m along Sion- Mahim link road from piwala Bunglow up to T-Junction in G/N ward.

Due Date of e-Tender: As on cover page.

Sr. No.	Brief description and office estimate
1.	City-

I/We have received, read and am/are agreeable to the content of page no. ____ to page no. ____ including the Bill of Quantities while quoting the percentages offered. I/We have considered the contents of the documents contained in the above mentioned pages and into thereof, I/We have signed the documents.

Name and Title of Signatory:

Name of Tenderer(s) :

Address :

E-Mail Address of the firm:

Telephone numbers :

**Digital Signature of Tenderer(s)
Trading under the Name and style of**

(A separate sheet must be filled, scanned and uploaded in packet B along with e-tendering)

SECTION – 18

BARRICADING CIRCULAR

MUNICIPAL CORPORATION OF GREATER MUMBAI
CIRCULAR

U/No. MGC/F/6342 dated 5.5.2018

Sub.: Revised guidelines regarding barricades being used during the execution of various infrastructure development projects by MCGM in Mumbai.

Various infrastructure development projects are being executed by MCGM for the betterment of citizens of Mumbai. During the course of execution of the projects, it is necessary to provide strong and secured barricading as a safety measure to avoid any mishaps as well as to avoid nuisance to vehicular and pedestrian traffic. Nowadays, the following types of barricades are being used exclusively in MCGM as per the convenience of various departments at different sites.

1. Water/sand fillable PVC Metro barricades.
2. RW 7.45 (G.I. sheets of 22 gauge fixed on 3 inch dia. Wooden bullies buried in existing road sufficiently)
3. RW 7.36 (G.I. sheets of 22 gauge fixed on MS Angle post buried in half the depth in drums of 20 liters capacity in 1:3:6 concrete).
4. Structural steel barricade for major trenches having depth more than 2.00 meters.

Thus from the above, it can be seen that there is no uniformity in provision of barricades as they are of different size and shape. Further it is also observed that the continuity is not maintained in providing the barricading keeping gaps in between thus endangering the safety of vehicular as well as pedestrian traffic. Also the barricades are not being cleaned, thus further adding to shabbiness. Further Mumbai being the financial capital of India, people from all over the world visit the city daily and to maintain good image of city the following decisions are taken.

- A) Only two type of barricades having department wise color coding are proposed to be used depending upon the nature of work i.e. Minor and Major.
- (v) **Minor works:** Barricading made out of 1.5 mm thick MS plate fixed on M.S. angle post/ frame of 65 mm X 65 mm X 6 mm having height of 1.5 m supported on as shown in Annex-I.
- (vi) **Major works:** Structural steel barricade made out of 1.50 mm thick M.S. Plate ISMB 250, ISLC 250X50mm and ISA 50mmX50mmX6 mm having of size 2.5 m X 2 m as shown in Annex-II.
- B) The department wise colour coding for the barricading shall be as under:-
- (i) H.E. & W.S.P. department – **Blue**
- (ii) Roads, Traffic, Bridges and Coastal Roads department – **Yellow**
- (iii) S.P. & S.O department – **Green**
- (iv) S.W.D., Building Maintenance department & for ward works – **Red**
- C) The basic principle behind installing secured and continuous barricading is to ensure the safety of vehicular as well as pedestrian traffic and residents in the nearby vicinity of the project. Due to non-installation of appropriate barricades on sites if any mishap occurs leading to injury or loss of

life, then the contractor and contractor's Engineer in-charge will be liable for the consequent action.

- D) During the course of execution of project, if it is noticed that the contractor has not provided barricading then a penalty of Rs.1000/- per meter per day will be imposed upon the contractor and will be deducted from the due Bill. This penalty shall be a part of penalty as per tendercondition.
- E) Details of the work shall be prominently displayed on the central panel of the barricades along-with the Social Slogans as given in Annexure III and the Cycle of the same shall be maintained.
- F) The contractor shall provide and install the barricading alongwith the slogans printed as per the Annexure III, at his own cost and no payment will be made for this, however the contractor shall quote the bid accordingly by considering the cost of barricading. The condition shall be included in the tender as given below. **“Barricading shall be provided free of cost as per Circular vide U/No.MGC/F/6342 dated 5.5.2018 and as per Annexure I, II and III of Standard drawings and specifications with slogans and department wise colour codes.”** The copy of circular will be attached to the tender as a part of tender document. This circular will be applicable for the new tenders proposed to be invited from 01.05.2018 and also the corrigendum shall be attached to tenders which are uploaded. However, for the projects wherein the tenders are already invited, the barricading shall be provided strictly as per tender condition. All the details (Annexure I, II & III of Standard drawings and specifications with slogans and department wise colour codes, sketches and department wise colour coding) are uploaded on MCGM portal.

This circular shall come in force with immediate effect.

ANNEXURE I

A) Minor work

Providing, fabricating and installing the barricading made out of 1.5 m high M.S. Angle post of 65 mm X 65 mm X 6 mm with 1.5 mm thick M.S. Sheet of size 1.55 m X 1.2 m welded to the M.S. angle post/ frames and fixed to 75mm X 75mm X 6 mm angle base as shown in sketch for minor works , displaying of the social slogan as per the Annex - III, daily cleaning of the same to get better appearance and interlocking arrangement to ensure continuity in provision and to avoid gap in between etc complete and as directed by Engineer in-charge.

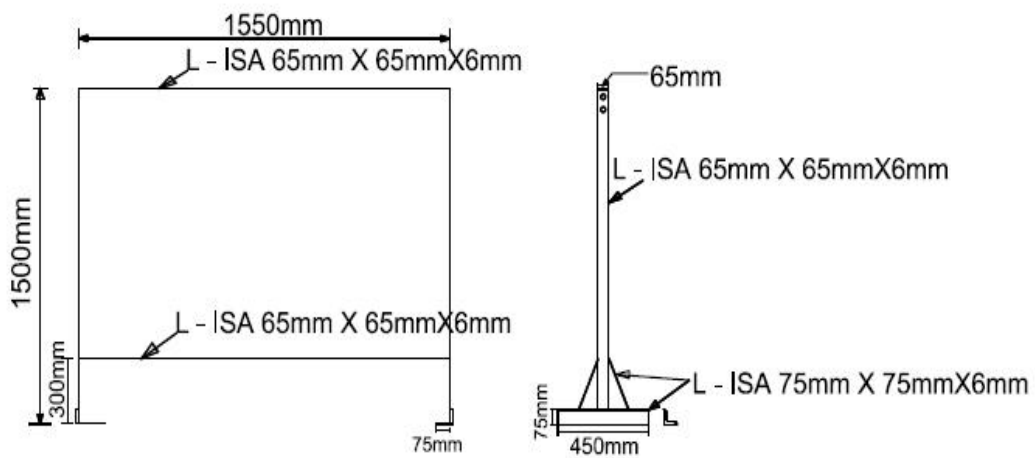

ANNEXURE II

B) Major works:

Providing, fabricating and installing the structural steel barricading made out of 1.5 mm thick M.S. plate of size 2500 mm X 2000 mm, ISMC 250 X 50 channels, M.S. Angles ISA 50 X 50 X 6mm and ISMB 250 as per IS 1161-1 RHS/SHS rolled angle plates of TATA Steel, Lloyd Steel, SAIL, ESSAR steel approved in straight profile of all sizes, shapes and for all works including stiffeners, bolts and nuts, fillet / butt welding, splicing, machine grinding, of all member joints wherever required to give neat appearance, and daily cleaning the barricading along with displaying of the Depthwise slogans as given in Annexure -III etc with interlocking arrangement to avoid gap in between and as directed by Engineer in-charge.

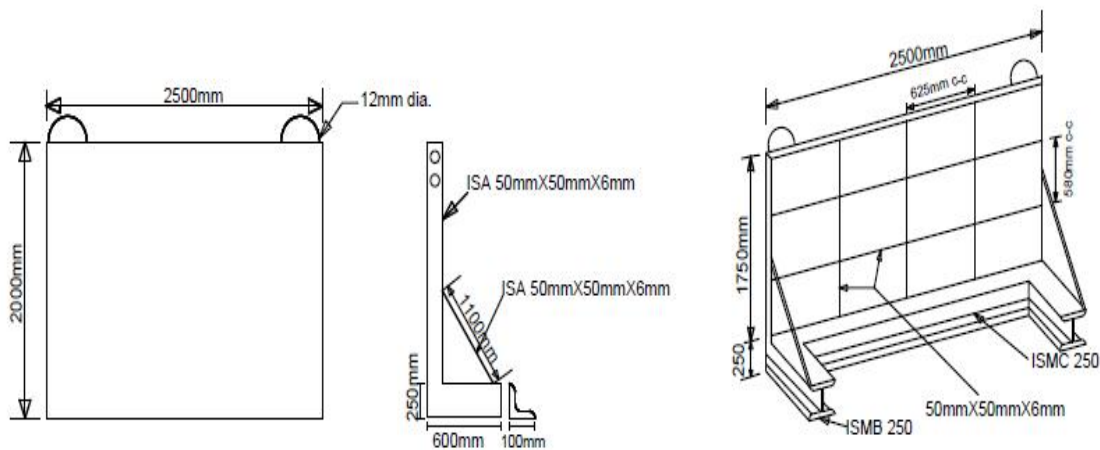

ANNEXURE III

1) HYDRAULIC ENGINEER'S DEPARTMENT/ WATER SUPPLY PROJECTS

- i) Inconvenience regretted
- ii) Ensuring Mumbai's water supply
- iii) Save water Save life

2) ROAD, TRAFFIC / BRIDGES DEPARTMENT

- i) Inconvenience regretted
- ii) Working towards a better tomorrow
- iii) My Mumbai, Green Mumbai

3) SEWERAGE PROJECTS DEPARTMENT/ SEWERAGE OPERATIONS DEPARTMENT

- i) Inconvenience regretted
- ii) Reduce Reuse Recycle
- iii) Clean Mumbai , healthy Mumbai

4) STORM WATER DRAIN DEPARTMENT/ WARD WORKS

- i) Inconvenience regretted
- ii) Working towards a better tomorrow
- iii) Swatch Bharat

